

A report prepared in support of the
Ontario Pork Industry Improvement Plan
Project #OP1037

**TRANSIENT NATURE OF HAZARDOUS CONDITIONS
IN SWINE BARNS DUE TO MANURE GAS
RELEASED DURING SLURRY MIXING**

by

S.P. Clarke
Ontario Ministry of
Agriculture & Food
Nepean, Ontario
K2H 6L2

N.K. Patni
Centre for Food and
Animal Research
Agriculture Canada
Ottawa, Ontario
K1A 0C6

Final report to
Mr. K.G. Boyd, General Manager, Research Programs
Ontario Ministry of Agriculture and Food
Guelph Agriculture Centre
Box 1030, Guelph, Ontario N1H 6N1

April 1992
(updated June 1992)

PROJECT SUMMARY

An investigation of the transient nature of hazardous conditions in swine barns due to manure gas released during slurry mixing.

The above study was initiated in June 1989 with support from the Ontario Ministry of Agriculture and Food (OMAF) under the Ontario Pork Industry Improvement Plan (OPIIP). The study was a collaborative effort of OMAF at Kemptville and Nepean, Ontario, and the Centre for Food and Animal Research (CFAR) of the Research Branch of Agriculture Canada in Ottawa, Ontario. The objective of the study was to investigate the nature of hazardous manure gas release, particularly hydrogen sulphide (H_2S), at the time of slurry mixing in commercial swine barns, and to determine if any specific manure properties or composition constituents can be related to the observed gas release.

A survey of swine producers in the summer of 1989 indicated that there was an insufficient number of swine farms with fully and partially slatted floors in Eastern Ontario to conduct a reasonably adequate comparative study. Consequently, most of the investigations were carried out at swine farms in south-western Ontario in the vicinity of Kitchener and Waterloo. From October, 1989, to October, 1991, a total of twelve farm sites were visited nineteen times to measure concentrations of H_2S , ammonia (NH_3) and carbon dioxide (CO_2) prior to, during and after mixing or movement of slurry under different "as is" conditions, with respect to barn layout, ventilation conditions, slurry age in storage pits, slurry mixing or agitation, animal age, time of year, etc. Gas concentrations were measured three different times at one finishing barn, twelve times at eight grower-finishing barns and three times at two grower barns, and once at a weaner barn. Eleven of these sites had fan ventilation and one site had natural ventilation. Continuous gas concentration monitoring was done using electrochemical sensors and dataloggers for H_2S , and long-term and diffusion-type gas detector tubes for all three gases, namely, H_2S , NH_3 , and CO_2 . In addition, spot measurements of these gases were also made at different times using short-term detector tubes.

One of the original intents was to compare gas concentrations at different farms with similar barn layout and management systems, and to make gas concentration measurements when the manure slurry pits were nearly full. In practice this was not possible because no two farm sites offered to us for gas concentration measurements had similar layout or management systems. Also, the manure pits were sometimes not full at the time of concentration measurements, even though we were given to understand that the pits would be near full on the designated day of measurement. The remoteness of the farm sites from the laboratories in the Ottawa area occasionally caused some logistics problems. Because of these difficulties, it was therefore decided to study manure gas release during slurry mixing under different "as is" farm conditions.

The main results from this study are:

1. Of the three soluble gases, H₂S, NH₃, and CO₂ released during slurry mixing, H₂S represents the greatest hazard to animal and operator safety. Gas concentrations can vary widely under apparently similar operational conditions. Negligible concentrations of H₂S exist inside the barns under normal ventilation when the slurry is undisturbed (Figures 13, 14, 15, 16, 17).
2. The hazard from H₂S gas results from an immediate and very rapid release of dissolved gas at high concentrations when slurry mixing or agitation starts (Figures 13, 15, 16, 17, 19). The most important factor in the control of the H₂S gas release seems to be slurry mixing and air movement in the barn rather than the composition of the manure or other factors. Lethal concentrations of H₂S were measured at the slat level at one farm where slurry was mixed by blowing air into the bottom of the pit using a vacuum tanker (Figure #17).
3. The greater the slurry turbulence and splashing in the pit free space, the greater and faster is the release of H₂S gas.

During mixing of slurry by circulation using a manure pump, much higher concentrations of H₂S gas were observed when the discharge nozzle was above the slurry surface compared to when it was submerged (Figures 13, 15, 19). Localized high gas concentrations existed in the barn as well as the pit exhaust air corresponding to the location of the splashing under the slats, which depended on the angle of the discharge nozzle in the pit below the slats (Figures 13, 15).

Concentrations of H₂S decrease rapidly when mixing/agitation is stopped, such as during tanker filling, and slowly with prolonged mixing as the dissolved gas is depleted from slurry (Figures 15, 16, 19).

4. It appears that properly located and adequately sized pit fans can effectively reduce H₂S gas concentration above the slats to below dangerous levels (Figure 13, 14, 20). In the sites visited for this study, H₂S concentrations above the slats did not generally reach dangerous levels whereas these levels were reached in the pit exhaust air. The pit ventilation rates at these sites were estimated to range from 8000 to 13,000 cubic feet per minute. Operation of barn exhaust fan during slurry mixing at one farm increased H₂S above the slats, compared to when the fan was shut off. (Figure 16, 18) At another farm, higher gas concentration was observed on the slats in the vicinity of a non-functioning pit fan compared to that near a well-functioning pit fan (Figure 20).

5. Under normal ventilation conditions, concentrations of NH_3 and CO_2 in the barn during slurry mixing are well below dangerous levels and do not represent an immediate hazard.

The following recommendations are made for reducing hazards during slurry mixing:

1. Well-functioning pit exhaust fans which are properly sized and located are valuable for the control of manure gas hazard inside the barn. This is because they draw the air from above the slats to below the slats and ventilate the free space above slurry surface. Installation of remote warning devices to indicate failure of pit fans due to power failure, for example, would be very useful during periods of unattended mixing of slurry in subfloor pits. These warning devices would indicate the need for urgent remedial action such as shutting off the manure pump before serious harm is done to livestock and workers from manure gas inhalation.
2. During slurry mixing, it is preferable to operate only the pit exhaust fans and not the barn exhaust fans. The latter tend to draw manure gas above the slats during slurry mixing. This is especially critical if pit fans fail and barn exhaust fans are still on, and during the winter when air inlets in the barn are adjusted for winter ventilation rates. It is also important when barn exhaust fans are more powerful than the pit exhaust fans. Proper design of the exhaust system is important.
3. Manure gas hazard can be reduced considerably by avoiding conditions that lead to splashing and free-falling of slurry, and by allowing adequate free space for the pit exhaust fans to be effective. A submerged recirculation pipe nozzle will release less gas and odorous compounds in the air than an exposed nozzle with splashing slurry in the free space. This would also reduce odour nuisance when slurry is pumped from the barn to an outdoor, open-top storage tank, or when slurry is pumped to tankers for hauling.
4. It is desirable to obtain data on the extent of H_2S gas hazard above the slats during simulated pit fan failure during slurry mixing in subfloor pits. Such data could not be obtained in this study because we were unable to find producers who were willing to remove hogs from the barn for gas testing experiments. All in/ all out production systems could be easily used for such tests.

Rapport préparé à l'appui du Programme d'amélioration
de l'industrie du porc de l'Ontario
Projet n° OP1037

**Nature transitoire des conditions dangereuses
qui existent dans les étables de porcs
en raison des émanations de gaz
pendant le mélange du lisier pâteux**

par

S.P. Clarke
Ministère de l'Agriculture
et de l'Alimentation
de l'Ontario
Nepean (Ontario)
K2H 6L2

N.K. Patni
Centre de recherches
alimentaires et
zootechniques
Agriculture Canada
Ottawa (Ontario)
K1A 0C6

Rapport final présenté à
M. K.G. Boyd, directeur général, programmes de recherche
Ministère de l'Agriculture et de l'Alimentation de l'Ontario
Centre agricole de Guelph
C.P. 1030, Guelph (Ontario) N1H 6N1

Avril 1992
(Document mis à jour en juin 1992)

SOMMAIRE DU PROJET

Enquête sur la nature transitoire des conditions dangereuses qui existent dans les étables de porcs en raison des émanations de gaz pendant le mélange du lisier pâteux

L'étude susmentionnée a été entreprise en juin 1989 avec l'appui du ministère de l'Agriculture et de l'Alimentation de l'Ontario (MAAO), dans le cadre du Programme d'amélioration de l'industrie du porc de l'Ontario (PAIPO). Elle est le fruit de la collaboration entre les bureaux du MAAO situés à Kemptville et à Nepean (Ontario) et le Centre de recherches alimentaires et zootechniques (CRAZ) de la Direction générale de la recherche d'Agriculture Canada à Ottawa (Ontario). L'étude avait pour objet d'enquêter sur la nature des gaz dangereux qui émanent du fumier, et plus particulièrement le sulfure d'hydrogène (H_2S), au moment du mélange du lisier pâteux dans les étables d'élevage commercial du porc, et de déterminer si des propriétés particulières du fumier ou ses composants pourraient influencer sur les émanations de gaz mesurées.

Une enquête menée auprès des éleveurs de porcs, à l'été 1989, a permis de montrer que le nombre d'exploitations de porcs de l'est de l'Ontario qui possèdent des planchers faits partiellement et complètement de lattes était insuffisant pour mener une étude comparative raisonnablement fiable. Par conséquent, l'on a surtout visité des exploitations de porcs du sud-ouest de l'Ontario, situés aux environs de Kitchener et de Waterloo. D'octobre 1989 à octobre 1991, douze exploitations ont été visitées au total dix-neuf fois, afin de mesurer les teneurs en H_2S , en ammoniac (NH_3) et en dioxyde de carbone (CO_2), avant, pendant et après le mélange ou l'agitation du lisier pâteux dans des conditions variables « en l'état », en ce qui concerne le plan d'ensemble de l'étable, les conditions d'aération, l'âge du lisier pâteux dans les fosses d'entreposage, son mélange ou son agitation, l'âge de l'animal, la période de l'année et d'autres paramètres. Les teneurs en gaz ont été mesurées trois fois à une étable d'engraissement, douze fois à huit étables de croissance-engraissement, trois fois à deux étables de croissance et une fois à une étable de sevrage. L'aération était effectuée par un ventilateur à onze de ces sites, et naturellement à un autre. On a effectué une surveillance continue de la teneur en gaz à l'aide de détecteurs électrochimiques et de consigneurs de données pour le H_2S , ainsi que de tubes de type diffusion pour la détection des trois gaz, soit le H_2S , le NH_3 et le CO_2 . De plus, la teneur de ces gaz a été mesurée par endroit à différents moments, à l'aide de tubes de détection à court terme.

Au départ, on voulait entre autres comparer les teneurs en gaz à différentes étables ayant un plan d'ensemble et des systèmes de conduite du troupeau semblables, et mesurer les teneurs en gaz lorsque les fosses de lisier pâteux étaient presque pleines. Cela n'a toutefois pas été possible dans la pratique, car on n'a pu constituer de paires ayant des plans d'ensemble ou des systèmes de conduite semblables parmi les sites d'élevage où on a pu mesurer la teneur en gaz. De plus, les fosses à lisier pâteux n'étaient pas toujours pleines au moment de la mesure de la teneur en gaz, même si on nous avait laissé entendre que les fosses seraient presque pleines le jour où l'on devait prendre les mesures. La distance entre les exploitations et les laboratoires de la région d'Ottawa a causé à l'occasion des problèmes logistiques. En raison de ces difficultés, on a décidé d'étudier l'émanation de gaz pendant

le mélange du lisier pâteux dans les différentes conditions « en l'état » qui existaient au moment de notre visite.

Voici les principaux résultats de l'étude

1. Des trois gaz solubles, H_2S , NH_3 et CO_2 qui se dégagent pendant le mélange du lisier pâteux, le H_2S présentait le plus grand risque pour la santé des animaux et de l'exploitant. Les teneurs en gaz pouvaient varier grandement dans des conditions opérationnelles apparemment semblables. Des concentrations négligeables de H_2S étaient dégagées dans les étables où l'aération était normale, lorsque le lisier pâteux n'était pas en agitation. (Figures 13, 14, 15, 16 et 17).
2. Le risque que pose le H_2S résulte du dégagement immédiat et très rapide de fortes concentrations de gaz dissous lorsque le mélange ou l'agitation débutent (Figures 13, 15, 16, 17 et 19). Les facteurs les plus importants pour limiter le dégagement de H_2S semblent être le mélange du lisier pâteux et l'aération de l'étable, plutôt que la composition du fumier ou d'autres facteurs. À une exploitation où de l'air était soufflé à l'aide d'une citerne à vide au fond de la fosse pour mélanger le lisier pâteux (Figure 17), des teneurs létales en H_2S ont été mesurées au niveau des lattes.
3. Plus la turbulence du lisier pâteux était grande et plus les éclaboussures dans la partie vide de la fosse étaient abondantes, plus le dégagement de H_2S était élevé et rapide.

Pendant le mélange du lisier pâteux par circulation à l'aide d'une pompe à lisier, on a observé des teneurs en H_2S beaucoup plus élevées lorsque la buse de décharge était située à la surface du lisier plutôt que submergée (Figures 13, 15 et 19). Des teneurs élevées en gaz ont été mesurées par endroit dans l'étable, ainsi que dans l'air évacué de la fosse là où il y avait éclaboussure sous les lattes. Elles dépendaient de l'angle de décharge des buses placées sous les lattes, dans la fosse (Figures 13 et 15).

Les teneurs en H_2S diminuaient rapidement lorsque le mélange et l'agitation arrêtaient, notamment lorsque l'on remplissait les citernes, et lentement après mélange prolongé, au fur et à mesure que le gaz dissous s'échappait du lisier pâteux (Figures 15, 16 et 19).

4. Il semble que des ventilateurs bien placés et de taille adéquate peuvent réduire efficacement la teneur en H_2S au-dessus des lattes sous des seuils ne posant pas de risque (Figures 13, 14 et 20). Aux sites visités au cours de l'étude, les teneurs en H_2S au-dessus des lattes ne posaient généralement pas de risque, contrairement à celles de l'air évacué de la fosse. À ces sites, le débit de renouvellement d'air dans la fosse était estimé être de 8 000 à 13 000 pieds cubes par minute. À une étable, la teneur en H_2S au-dessus des lattes a augmenté lorsque l'on a mis en marche un ventilateur d'évacuation de l'air pendant le mélange du lisier pâteux (Figures 16 et 18). À une autre exploitation, la teneur en gaz au niveau des lattes près d'un

ventilateur d'aération de la fosse ne fonctionnant pas, était supérieure à celle près d'un ventilateur qui fonctionnait bien (Figure 20).

5. Dans des conditions normales d'aération, les teneurs en NH_3 et en CO_2 qui ont été mesurées dans l'étable pendant le mélange du lisier pâteux, étaient largement inférieures aux seuils dangereux et ne présentaient pas de risque immédiat.

L'application des recommandations suivantes aidera à réduire les risques pendant le mélange du lisier pâteux

1. L'emploi de ventilateurs d'aération de la fosse en bon état de fonctionnement, de taille adéquate et bien situés, aide à réduire le risque que posent les gaz dégagés par le fumier à l'intérieur de l'étable. Les ventilateurs entraînent sous les lattes l'air qui est situé au-dessus de ces dernières, et aèrent l'espace libre à la surface du lisier pâteux. L'installation de dispositifs à télécommande d'avertissement du mauvais fonctionnement des ventilateurs d'aération de la fosse, causé par exemple par une panne d'électricité, serait très utile lorsque le mélange du lisier pâteux dans les fosses situées sous le plancher n'est pas surveillé. Ces dispositifs d'avertissement signaleraient le besoin de prendre des mesures urgentes comme éteindre la pompe à lisier, avant que l'inhalation des gaz qui émanent du fumier ne nuisent gravement à la santé du bétail ou des travailleurs.
2. Pendant le mélange du lisier pâteux, il est préférable de faire fonctionner seulement les ventilateurs d'évacuation de l'air de la fosse et non ceux d'évacuation de l'air de l'étable. Ces derniers ont tendance à aspirer au-dessus des lattes les gaz dégagés pendant le mélange du lisier pâteux. Cela est particulièrement important si les ventilateurs d'évacuation de l'air de la fosse sont en panne et ceux de l'étable fonctionnent encore, et pendant l'hiver lorsque les bouches d'entrée d'air de l'étable sont ajustées en fonction de la saison. Il s'agit également d'une précaution qu'il est important de prendre lorsque les ventilateurs d'évacuation de l'air de l'étable sont plus puissants que ceux d'évacuation de l'air de la fosse. Il est également important que le système d'évacuation de l'air soit bien conçu.
3. On peut réduire sensiblement le risque que posent les gaz dégagés par le fumier en évitant les conditions qui mènent à l'éclaboussure et à la chute libre du lisier pâteux et en laissant un espace vide adéquat pour permettre le bon fonctionnement des ventilateurs d'évacuation de l'air de la fosse. Une buse submergée fixée à un tuyau de recirculation dégagera moins de gaz et de composés nauséabonds dans l'air qu'une buse exposée qui provoquera des éclaboussures du lisier pâteux dans l'espace vide. Cette technique permet également de réduire les mauvaises odeurs lorsqu'une pompe sert à acheminer le lisier pâteux de l'étable vers une cuve de stockage découverte, ou dans des réservoirs en vue de son transport.
4. Il est souhaitable de recueillir des données sur l'importance du risque que pose le H_2S au-dessus des lattes, lors d'essais simulant la panne du ventilateur de la fosse au moment du mélange du lisier pâteux dans les fosses situées sous le plancher. Ces données n'ont pu être

obtenues, parce qu'aucun éleveur n'était prêt à évacuer ses porcs de l'étable pour effectuer des expériences sur la teneur en gaz. Des systèmes de production avec entrée et évacuation complètes d'air pourraient facilement être utilisés pour réaliser de telles épreuves.

ACKNOWLEDGEMENTS

The study was partially supported by the Ontario Ministry of Agriculture & Food, under the Pork Industry Improvement Plan.

The co-operation and assistance of the following producers, who allowed their facilities to be used for the study, is greatly appreciated: Avon Farms, F. Danke, Frey Brothers, Hay Bay Farms, A. Hakvort, G. Jantzi, C. Knorr, Maple Farms, D. McMillan, and A. de Witt.

The assistance of R. Allen, D. Campbell, R. Honkoop, D. Trudell and R. Williams in gas concentration measurement, manure analysis and data processing is gratefully acknowledged. Whenever needed, helpful advice on the conduct of this study was provided by Mr. Ken Boyd and his staff at the OMAF Research Programs Office. This was very much appreciated.

INTRODUCTION

A study of the transient nature of hazardous conditions in swine barns due to manure gas release during slurry mixing was initiated in June, 1989. This study was partially supported by the Ontario Ministry of Agriculture and Food under its Ontario Pork Industry Improvement Plan. It was a collaborative effort of OMAF at Kemptville and Nepean and the Centre for Food and Animal Research of Agriculture Canada at Ottawa. The objective of the study was to investigate the nature of hazardous manure gas release, particularly hydrogen sulphide (H_2S) gas, at the time of slurry mixing in commercial swine barns, and to determine if any specific manure properties or composition constituents can be related to the observed gas release. The other manure gases whose concentrations were studied were ammonia (NH_3) and carbon dioxide (CO_2). This report describes the procedures used in the study, and the main results, conclusions and recommendations.

THE STUDY PROCEDURE

Study Sites: Several swine producers were contacted for the use of their facilities for measurement of gas concentrations. Since there was an insufficient number of farms in Eastern Ontario which had manure pits under slatted or partially slatted floors, most of the gas concentration measurements were made in South-Western Ontario in the vicinity of Kitchener-Waterloo. Details of the farm sites used for manure gas measurements are summarized in Table #1. During the period of October, 1989, to October, 1991, a total of twelve different sites at ten producer locations were visited nineteen times. Measurements were made at these sites once, twice or three times on different occasions. Concentrations were measured three times in a finishing barn, twelve times in grower-finishing barns, three times in grower barns, and once in a weaner barn. Fan ventilation was used at eleven sites and natural ventilation at one site (Farm Site 12 in Table 1). Sixteen of the eighteen measurements were made at barns with fully slatted floors over sub-floor manure pits. Two sites had partially slatted floors above gutter systems. The layout of the barns and the gas measurement locations during each visit to the different farm sites are shown in Figures 1 to 12.

Study Procedure: All gas concentration measurements were made on the day of slurry mixing, prior to, during and immediately following the mixing operation. Concentrations were measured under normal operational and ventilation conditions. Pit exhaust fans were in operation at the sites that were so equipped. To obtain concentration measurements under the worst possible situation, the intent was to have manure pits nearly full at the time of mixing and concentration measurements. Because of farm operational circumstances, this situation did not exist every time. However, the manure pits were at least 50% full, when the measurements were made. Except at one site, the animals were not removed from the barns. They were removed from specific pens where equipment was placed on the floor to measure concentrations at the floor level. At the one site where the animals were removed from the barn, some pig mortalities had been experienced in the past, so it was a normal practice to remove the animals at the time of slurry mixing. Gas concentrations were measured at different locations where concentrations were expected to be near the maximum in the barns, at the floor level and about 3 feet above the floor. Only H₂S gas concentration was monitored in the pit exhaust air. Measurement locations for different gases in the barns are indicated in Figures 1 to 12.

Gas Concentration Measurement Equipment: One-minute average concentrations of H₂S were monitored at up to six different locations using electrochemical H₂S sensors and associated dataloggers made by Compur-Electronic GmbH, Munich, Germany, and/or National Draeger Inc., Pittsburgh, Pennsylvania, U.S.A. The nominal detection limit of the H₂S sensors was 100 and 200 ppm for the Compur and Draeger units, respectively. The sensor cells were calibrated prior to and after each use. The calibration was done using standard H₂S/nitrogen mixtures produced by blending of a standard H₂S/nitrogen mixture with different proportions of air using mass flow controllers (Matheson Gas Co., Whitby, Ontario). Draeger long-term and diffusion-type gas detector tubes were used to determine time-weighted average concentrations of NH₃, CO₂, and H₂S. Draeger Polymer peristaltic pumps were used with the longterm tubes. Draeger short-term detector tubes and bellows pumps were used for spot checks.

Manure Samples: Manure samples were collected for analysis prior to and following mixing. Often, manure was being hauled to the fields while mixing was in progress. Because most of the manure pits were below slatted floors, and accessible sampling sites were very few, it was not possible to determine how well the slurry was mixed at the time of sampling. Temperature, pH, conductivity, dry matter, total nitrogen and ammonia nitrogen, and volatile fatty acids were determined in the slurry samples. Slurry pH is a measure of acidity; lower the pH, more acidic the slurry. Conductivity is an indicator of mineralization of slurry. Ammonia nitrogen is the readily available form of nitrogen for crop use.

RESULTS AND FINDINGS

Acceptable Gas Concentrations in Workplace: At present there are no standard or guideline values for acceptable or non-acceptable gas concentrations in confined animal buildings. The American Conference of Governmental Industrial Hygienists (ACGIH, 1983) specifies the following three categories of Threshold Limit Values (TLVs®) for gas concentrations for human exposure to gases and vapours under industrial practice.

1. Threshold Limit Value-Time Weighted Average (TLV-TWA). The time-weighted average concentration for a normal 8-hour workday and a 40-hour work week to which nearly all workers may be repeatedly exposed, day after day, without adverse effect.
2. Threshold Limit Value-Short Term Exposure Limit (TLV-STEL). The maximum concentration to which workers can be exposed for a period up to 15 min. continuously without suffering from: 1) irritation, 2) chronic or irreversible tissue change, or 3) narcosis of sufficient degree to increase accident proneness, impair self-rescue, or materially reduce work efficiency, provided that no more than four excursions per day are permitted, with at least 60 minutes between exposure periods, and provided that the daily TLV-TWA also is not exceeded. The STEL should be considered a maximal allowable concentration, or ceiling, not to be exceeded at any time during the 15-min excursion period.
3. Threshold Limit Value-Ceiling (TLV-C). The concentration that should not be exceeded even instantaneously.

The TLVs and other characteristics of the main manure gases are given in Table 2. There are no specified TLV-C values for H₂S, NH₃, CO₂ and methane (CH₄). Methane concentrations were not determined in this study because CH₄ is not considered to present a hazard in ventilated barns. It should be noted that the above TLVs relate to industrial conditions and not farm conditions. These are shown here only as a reference or benchmark for the discussion of results in the next section.

Gas Concentrations in the Barns: Gas concentrations measured under different types of barn management and operational conditions (Table 1) are summarized in Table 3. Concentrations of ammonia and carbon dioxide gases were always well below danger or hazard levels under normal ventilation, with or without slurry mixing or agitation. This was also true for H₂S gas, except when manure slurry was disturbed by agitation or mixing, at which time concentrations rose rapidly, within a few minutes, to very high values. The danger to operators and livestock is from this sudden rise in H₂S concentration, sometimes to lethal or to near-lethal levels which could cause illness or injury. Concentrations decrease rapidly when agitation is stopped, or slowly with continued agitation, as the

dissolved gas is gradually released from solution. Slurry agitation and mixing produced drastic changes in the concentration of H_2S but not NH_3 and CO_2 .

Concentrations of all three gases varied with time and location inside the barns, depending on local conditions of air movement and the degree of slurry agitation below the slats. Certain operational procedures affected concentrations of H_2S gas in the barn air and pit exhaust air. It was observed that increased slurry turbulence and splashing in the pit free space increased not only the concentration but also the rate of release of H_2S gas, that is, higher gas concentrations were reached in shorter times. Thus, concentrations were lower when slurry was mixed by circulation using a submerged rather than an exposed recirculation pipe or nozzle. Localized high gas concentrations were observed in the barn as well as in the pit exhaust air corresponding to the location of splashing under the pits as determined by the angle of the discharge nozzle under the slats. The fastest release of H_2S gas was observed to occur when air was blown into the slurry for mixing, using vacuum tankers.

Pit exhaust fans were found to be effective in reducing H_2S concentrations above the slats in the barns to below-danger levels. Concentrations in the pit exhaust air were almost always substantially higher than in the barn air at the same time during measurements. Proper design of pit and barn exhaust fans in terms of size and location is essential for reducing manure gas hazard in the barn during slurry mixing. The pit ventilation rates at the sites visited were estimated to range from 8,000 to 13,000 cubic feet per minute. At one farm, operation of barn exhaust fan during slurry mixing increased H_2S above the slats, compared to when the fan was shut off. At another farm which had a larger fan for barn exhaust than for pit exhaust air, H_2S concentrations tended to be higher in the barn than in the pit exhaust. This indicates the need for proper design of ventilation systems to reduce manure gas hazard.

As noted above, gas concentrations were monitored in the barns at different locations as shown in Figures 1 to 12. The maximum concentrations of H_2S and the range of average concentrations of the three gases at these various locations are shown in Table 3. Farm sites 1, 2 and 10 had low, maximum and average concentrations of H_2S in the barn air partly because slurry was mixed at these sites by recirculation via submerged pipe (Table 1) with normal operation of pit exhaust fans. Farm site 9 had a similar mixing operation except that the fans were of 24" diameter for barn exhaust and only 12" for pit exhaust and the tank was full of manure with little free space under the slats. This may partly explain the high concentrations of H_2S in barn air at this site, compared to sites 1, 2 and 10.

Sites 11 and 12 had relatively low H_2S concentrations as well because the gutters at these sites were only 2' deep, and the manure was removed by gravity flow every week at Site 11 and every two

weeks at Site 12. Thus, the manure at these sites was not sufficiently anaerobic to release large quantities of H₂S.

At Farm sites 3, 5, 6 and 7, manure was mixed using a submerged centrifugal pump and a discharge pipe with a nozzle whose height could be adjusted such that the nozzle could be above or below the slurry surface. High H₂S concentrations in both the pit and barn exhaust air were observed at these sites when the manure was discharged from the nozzle above the slurry surface with considerable splashing. Figures 13 to 20 show H₂S gas concentrations observed at these sites. The observations are explained in the captions accompanying these figures.

Slurry was mixed by blowing air into the slurry at Farm Sites 4 and 8. It was at these sites that very high H₂S concentrations were measured almost as soon as the air bubbling started. Pit exhaust fans at Site 4 (Figure 4) kept H₂S concentrations considerably lower than at Site 8 (Figure 8) which had no pit exhaust. Concentrations up to 1,000 and 1,300 ppm H₂S measured on slats at Site 8 are sufficient for possible fatalities. The operator at Site 8 had reportedly lost some pigs to manure gas earlier, and the standard practice after that was to remove the hogs from the barn at the time of slurry mixing.

In view of the above results, an attempt was made to determine the extent of H₂S gas hazard inside the barns during slurry agitation in the event of a failure of pit fans. Through the Ontario Pork Producers Marketing Board, a request was made to producers with all in/all out production systems to make their sites available for H₂S concentration measurements above slats during slurry mixing with all the animals removed from the barns during testing. This request did not receive an adequate response to obtain meaningful data. This information would be very useful to indicate the extent of the hazard that operators and animals could face under conditions of pit fan failure during slurry mixing.

Manure Composition and its Relation to observed Gas Concentrations: Manure slurry properties and composition are given in Table 4. As mentioned above, it was not always possible to establish if the slurry was completely mixed after the mixing operation was stopped.

Most of the site visits were made in the months of May and October when the slurry temperature was mostly between 15 and 20°C. The dates of site visits are given in Figures 1 to 12. Some temperature data could not be obtained because the glass thermometers broke and a replacement could not be readily obtained. The slurry pH ranged from 6.5 to 8.1, and the conductivity from 3 to 33 millimho per cm at 25°C. One would expect conductivity to be higher in the slurry stored at higher

temperatures because of greater mineralization than at lower temperatures. However, slurry conductivity was not consistently higher for slurry with higher temperature.

Slurry dry matter ranged from a low of 0.5% to a high of 11.6% by weight. This wide variation resulted from a number of factors such as settling of solids (in samples collected near surface, prior to start of mixing), age of slurry, animal age and diet, amount of water leakage into slurry pit, amount of oxidation of organic matter in the slurry, incomplete mixing of slurry, etc. In spite of the wide variation in slurry dry matter, the total nitrogen in the slurry did not vary to the same extent. More interestingly, a large proportion of the total nitrogen was in the ammonia form which is the readily available form of nitrogen for crop use. The total volatile acids in the slurry (centrifuged supernatant) varied widely also. Volatile acids are easily degraded so the wide range of concentrations observed probably reflects various degrees of volatile acid degradation (and production) in the slurry.

The gas concentrations observed in the barns as well as the various slurry properties and composition constituents varied too widely to permit a meaningful analysis of data which could be used to relate gas release to any manure characteristics. It is unlikely that a study of the type conducted here could be used to establish such a link. Controlled laboratory or barn studies would be necessary for this.

PUBLICATIONS

Publications resulting from this work are listed below. Some additional details are included in these publications.

Patni, N.K. and Clarke, S.P. 1991. Transient hazardous conditions in animal buildings due to manure gas released during slurry mixing. *Applied Engr. in Agriculture* 7:478-484.

Patni, N.K. and Clarke, S.P. 1990. Transient nature of hazardous conditions in animal buildings due to manure gases released during slurry mixing and removal. In: *Agricultural and Food Processing Wastes. Proc. Sixth Intl. SGMP. Agricultural and Food Processing Wastes, Amer. Soc. Agric. Engr., St. Joseph, Michigan*, pp. 449-459.

Patni, N.K. and Clarke, S.P. 1991. Hydrogen sulphide and other gases in swine barns during slurry mixing. Paper No. 91-227, *Can. Soc. Agric. Engr., Saskatoon, Sask.*, 22 pp.

Patni, N.K. and Clarke, S.P. 1990. Transient nature of hazardous conditions in swine barns due to manure gases released during slurry mixing. *Ontario Swine Research Review* 1989. OMAF, Guelph. pp. 40-46.

Patni, N.K. and Clarke, S.P. 1991. Hazardous conditions in swine barns during slurry mixing due to hydrogen sulphide gas. *Ontario Swine Research Review* 1990. OMAF, Guelph. pp 8-15.

CONCLUSIONS AND RECOMMENDATIONS

The main results, conclusions and recommendations of this study are included in the project summary at the beginning of this report. In brief, transient hazardous conditions can occur in swine barns due to sudden bursts of hydrogen sulphide gas release at high concentrations when manure slurry is disturbed or agitated. In barns with a reasonably well-designed barn and manure pit air exhaust system, the hazard from very high concentrations of ammonia and carbon dioxide is essentially absent. The hazard to operators and animals from transient high concentrations of H₂S gas inside the barn appears to be considerably reduced with well-functioning pit exhaust fans. Failure of pit fans during unattended slurry mixing in pits beneath slats could lead to serious injury to livestock. Actual data under such conditions do not appear to exist, and are worth obtaining.

TABLE 1: DETAILS OF FARM SITES USED FOR MANURE GAS MEASUREMENTS

FARM SITE NO. VISIT NUMBER	BARN AREA FT X FT	MANURE PIT AREA FT X FT	MANURE PIT DEPTH FT	MANURE DEPTH IN PIT FT	FLOOR ¹ TYPE	MIXING ² METHOD	ANIMAL ³ TYPE	APPROX. No. OF HOGS
1.1 1.2 1.3	40 X 49	40 X 63	10	6 5 5	FS	RP	F	FULL
2	30 X 64	30 x 64	6	4	FS	RP	G	340
3.1 3.2	40 X 50	50 X 55	10	5	FS	SP	G-F	325
4.1 4.2	36 X 90	two pits 49 X 42 39 X 42	10	10 4	FS	AB	G-F	285
5.1 5.2	36 X 70	41.5 X 80	8	4.5 3.75	FS	SP	G-F	336
6.1 6.2	36 X 120	36 X 130	8	6 3.3	FS	SP	G	600
7	40 X 70	44 X 70	8	6	FS	SP	G-F	330
8.1 8.2	10 X 34	6 X 8.5	8	7 7	PS	AB	G-F	30
9	25 x 30	25 X 30	8	7	FS		W	100
10	36 X 170	36 X 170	8	8	FS	RP	G-F	600
11	36 X 130	two gutters 4 X 130	2	1.5	PS	GF	G-F	500
12	44 X 70	Central gutter 12 X 120 End pit 14 X 14 X9	2	2	PS	GF	G-F	600

1. FS - Fully Slatted; PS - Partially Slatted
2. RP - Recirculation pto Pump; SP - Submerged Pump; AB - Air Blowing; GF - Gravity Flow
3. W - Weaner; G - Grower; G-F - Grower - Finshing; F - Finishing

Table 2. Properties, Characteristics and TLVs of Manure Gases

Property or characteristic	Manure gas			
	Hydrogen Sulphide	Ammonia	Carbon Dioxide	Methane
Specific gravity	1.2	0.6	1.5	0.6
Odor	rotten egg	pungent	none	none
TLV-TWA ppm ^a	10	25	5,000	none ^b
TLV-STEL ppm ^a	15	35	15,000	none ^b
Hazard level	500	2000	30,000	b

^a TLV = Threshold Limit Value; TWA = Time Weighted Average (normally 8 hrs.); STEL = Short Term Exposure Limit (normally 15 minutes); ppm = parts per million by volume;

^bAsphyxiant, forms explosive mixture with air at concentrations of 50,000 and 150,000 ppm (5 to 15%) by volume.

Source:

1. American Conference of Governmental Industrial Hygienists, 1983. Threshold Limit Values for Chemical Substances and Physical Agents in the Work Environment with Intended Changes for 1983-84. ACGIH, Cincinnati, Ohio.
2. Agriculture Canada, 1979, Canada Animal Manure Management Guide. Publication 1534, Ottawa, Ontario.

TABLE 3. SUMMARY OF GAS CONCENTRATIONS AT DIFFERENT FARM SITES

Farm Site No. and Visit No.	Max. H ₂ S Concentration observed during measurement - ppm		Average Concentration of gas at various locations during measurement period - ppm			
	Pit exhaust air	Barn air - floor or 3' above	Barn Air NH ₃	Barn Air CO ₂	Pit Exhaust air H ₂ S	Barn Air H ₂ S
1.1	NM	0	9 - 19	2200 - 2500	NM	0
1.2	15	0	3 - 7	1300 - 2300	0 - 2	0
1.3	19	0	8 - 9	2500 - 3000	0 - 3	0
2	112	3	10 - 16	2000 - 2000	0 - 19	0
3.1	116	100+	8 - 12	1200 - 1400	16-74	4 - 10
3.2	236	50	6 - 10	1800 - 2200	2 - 11	0
4.1	222	10	18 - 22	3000 - 5000	0 - 13	0
4.2	44	20	10 - 18	2000 - 4000	0 - 1	0
5.1	272+	45	11- 28	1300 - 1900	2 - 39	2 - 4
5.2	365	64	3 - 7	1300 - 1400	72 - 164	5 - 9
6.1	262	213	28 - 38	2500 - 2500	3 - 28	8 - 15
6.2	140	129	11 - 23	2300 - 5100	4 - 6	2 - 5
7	179	165	10 -20	3000 - 5000	10 - 11	4 - 10
8.1	NA	1300'	38 - 275	NM	NA	9 - 98
8.2	NA	1000	NM	NM	NA	2 - 30+
9	61	220	11 - 14	900 - 1100	1	4 - 33+
10	0	0	NM	NM	0	0
11	NA	2	20 - 90	0 - 5	NA	0
12	NA 48 ppm in pit free space	9	NM	5000 - 8000	NA	2

ppm = parts per million

NM - Not measured

NA - Not applicable

* detection tubes on slate

TABLE 4 - SLURRY PROPERTIES AND COMPOSITION AT DIFFERENT PARK SITES

Farm Site No. Visit No.	Sampling before (B) or after (A) mixing	Sampling depth (feet)	Temp /C	pH	Conductivity at 25°C mmho/cm	Dry Matter %	Total Nitrogen %	Ammonia Nitrogen %	Total Volatile Acids mmole/L
1-1	B	2	17	7.8	10.47	0.8	0.2	0.20	NM
	B	4	17	7.3	10.90	6.4	0.3	0.25	NM
1-2	B	2	16	7.2	7.23	1.1	0.28	0.28	15
		4	16	7.2	7.26	1.1	0.29	0.29	12
	A	2	16	7.2	8.23	1.1	0.29	0.27	10
		4	16	7.2	7.80	1.1	0.29	0.28	18
1-3	B	2	16	7.2	6.71	1.2	0.29	0.27	10
		4	16	7.1	6.45	2.3	0.34	0.30	10
	A	2	16	7.2	6.36	2.0	0.34	0.29	13
		4	16	7.1	6.20	2.0	0.35	0.30	14
2	B	2	19	7.0	9.46	0.9	0.11	0.09	HM
		4	20	6.9	8.22	10.8	0.27	0.19	NM
3-1	B	2	20	7.3	15.83	2.4	0.23	0.20	NM
		4	20	7.4	16.08	5.6	0.31.	0.27	NM
3-2	B	2.5	NM	7.8	19.30	2.8	0.4	0.36	5
	A	2		8.0	21.00	2.3	0.38	0.36	10
4-1	Pit 1, B	3	15	7.4	9.17	0.5	0.27	0.26	18
	Pit 2, B	3	15	7.4	9.88	1.6	0.36	0.24	3
4-2	B	2	NM	7.9	3.31	2.1	0.36	0.32	2
	A	2	NM	8.1	3.61	1.4	0.33	0.32	5
5-1	B	2	22	7.4	11.00	3.6	0.56	0.54	79
	A	2	24	7.6	11.00	3.9	0.62	0.53	104

TABLE 4 - (CONT'D) SLURRY PROPERTIES AND COMPOSITION AT DIFFERENT FARM SITES

Farm Site No. Visit No.	Sampling before (B) or after (A) mixing	Sampling depth (feet)	Temp °C	pH	Conductivity at 25°C mmho/cm	Dry Matter %	Total Nitrogen %	Ammonia Nitrogen %	Total Volatile Acids mmole/L
5-2	B	2	NM	7.6	17.30	3.7	0.51	0.49	211
	A	2	NM	7.7	19.40	6.7	0.54	0.51	20
6-1	B	2	24	7.6	12.20	1.2	0.27	0.27	2
	A	2	24	7.6	17.20	1.5	0.30	0.30	2
6-2	A	2	NM	7.7	29.10	1.3	0.30	0.29	22
7	A	2	NM	7.7	33.10	2.3	0.41	0.36	245
8-1	A	2	NM	7.5	21.60	1.6	0.41	0.38	101
9	B	2	NM	7.8	30.80	0.9	0.29	0.27	2
	A	2	NM	7.7	28.00	2.6	0.30	0.29	1
10	A	2	NM	7.8	27.70	1.4	0.31	0.31	12
11	B	1	9	6.9	18.43	11.6	0.70	0.37	255
12	B PIT	2	5	6.5	4.48	0.5	0.08	0.08	43
	A PIT TRENCH	2	4	6.5	7.72	1.8	0.21	0.14	58

NM - not measured

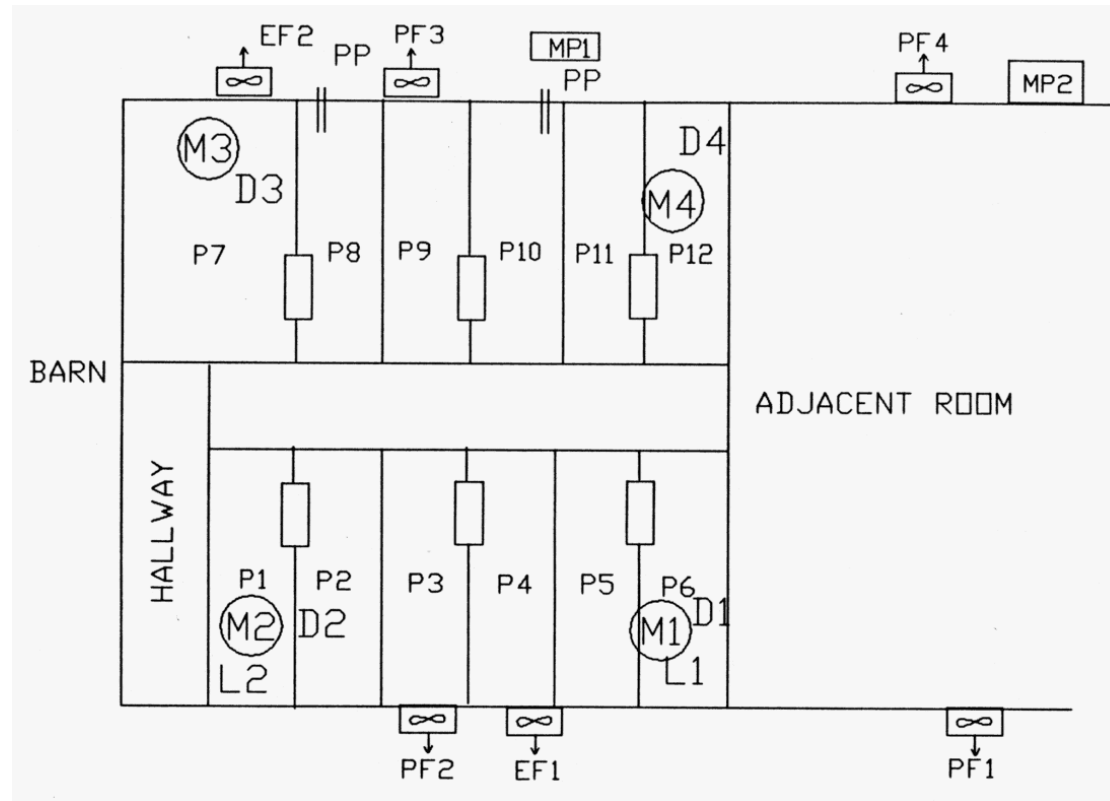

Date of Visit: 89-10-23
 90-05-23,24
 Barn Size: 40 ft x 40 ft
 P = Pen; MP = Manure Pump
 F = Feeder; PP = Pumping Port

M = H₂S, Continuous Monitoring Location
 D = NH₃, CO₂, H₂S Diffusion Tubes
 L = NH₃, CO₂, H₂S Long-Term Tubes
 EF= Exhaust Fan; PF = Pit Fan

FIGURE 1.1 - SCHEMATIC OF GAS MONITORING AT FARM SITE 1, VISIT NUMBER 1, 2, 3

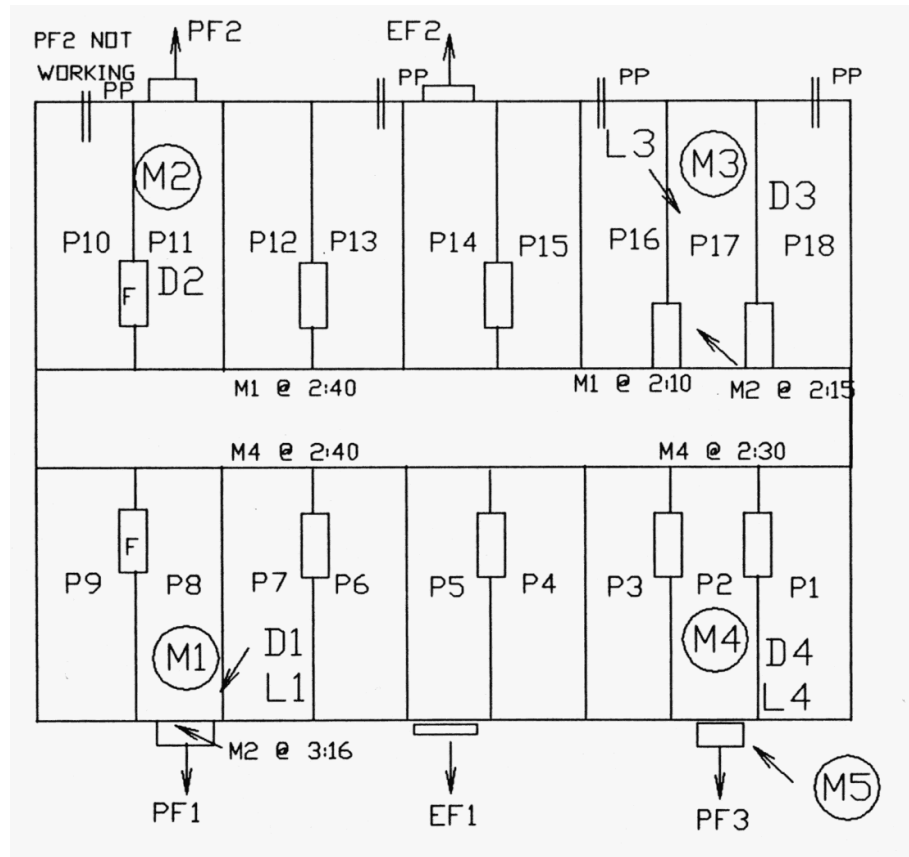

Date of Visit: 89-10-24
 Barn Size: 30 ft x 63 ft.
 P = Pen; MP = Manure Pump
 F = Feeder; PP = Pumping Port

M = H₂S, Continuous Monitoring Location
 D = NH₃, CO₂, H₂S Diffusion Tubes
 L = NH₃, CO₂, H₂S Long-Term Tubes
 EF= Exhaust Fan; PF = Pit Fan

FIGURE 2.0 - SCHEMATIC OF GAS MONITORING AT FARM SITE 2,

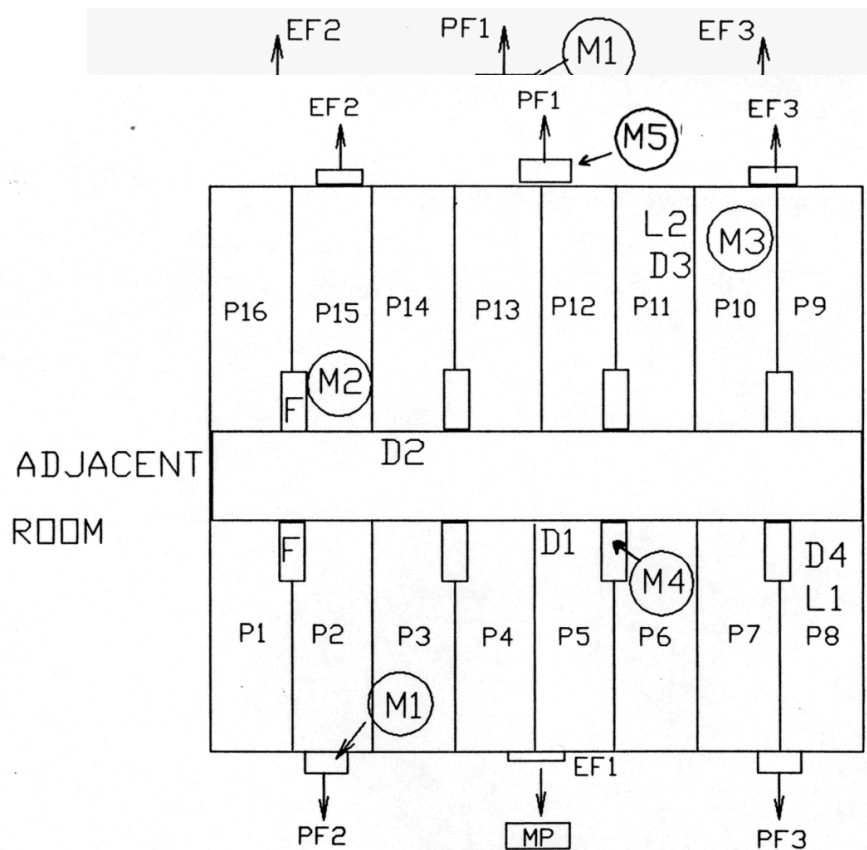

Date of Visit: 89-10-25
 Barn Size: 40 ft x 50 ft.
 P = Pen; MP = Manure Pump
 F = Feeder; PP = Pumping Port

M = H₂S, Continuous Monitoring Location
 D = NH₃, CO₂, H₂S Diffusion Tubes
 L = NH₃, CO₂, H₂S Long-Term Tubes
 EF = Exhaust Fan; PF = Pit Fan

FIGURE 3.1 - SCHEMATIC OF GAS MONITORING AT FARM SITE 3, VISIT NUMBER 1.

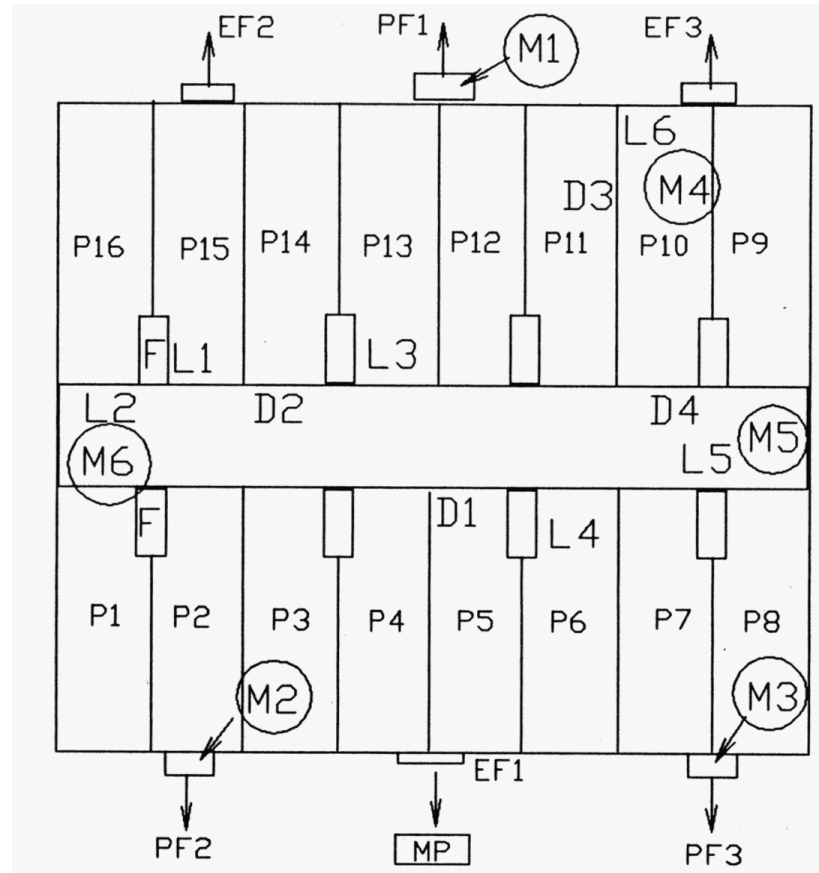

Date of Visit: 90-10-02
 Barn Size: 40 ft x 50 ft.
 P = Pen; MP = Manure Pump
 F = Feeder; PP = Pumping Port

M = H₂S, Continuous Monitoring Location
 D = NH₃, CO₂, H₂S Diffusion Tubes
 L = NH₃, CO₂, H₂S Long-Term Tubes
 EF = Exhaust Fan; PF = Pit Fan

FIGURE 3.2 - SCHEMATIC OF GAS MONITORING AT FARM SITE 3, VISIT NUMBER 2.

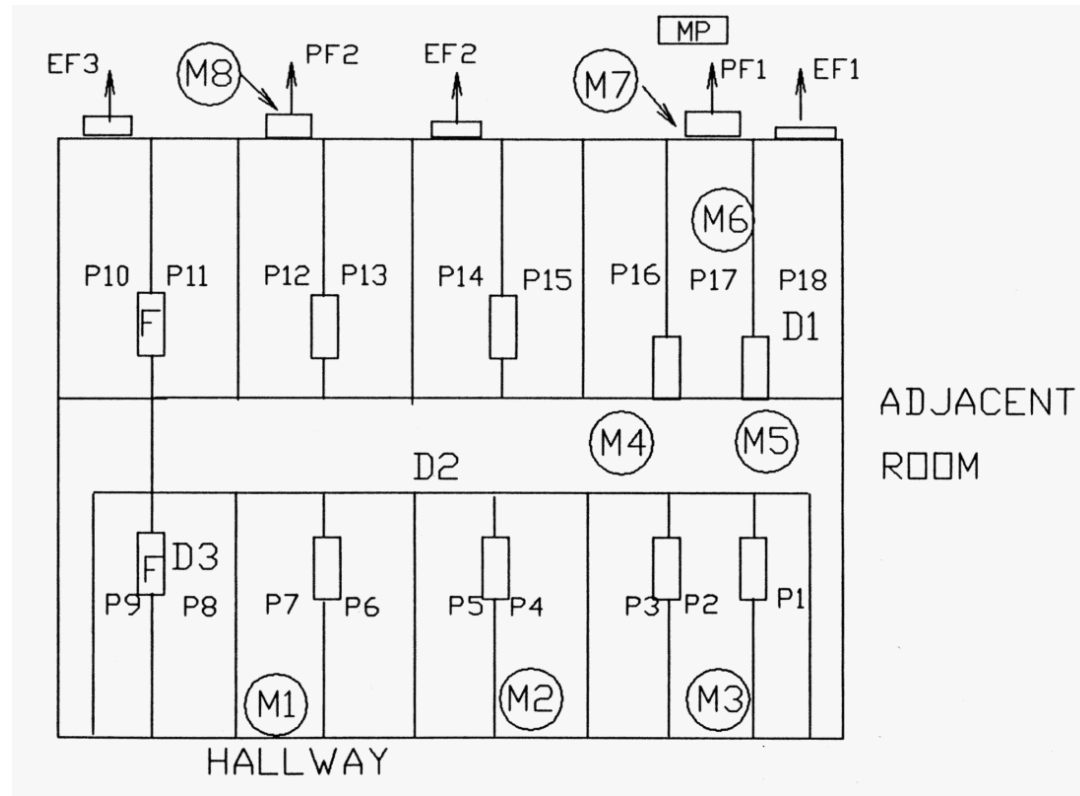

Date of Visit: 90-04-20
 Barn Size: 36 ft x 90 ft.
 P = Pen; MP = Manure Pump
 F = Feeder; PP = Pumping Port

M = H₂S, Continuous Monitoring Location
 D = NH₃, CO₂, H₂S Diffusion Tubes
 L = NH₃, CO₂, H₂S Long-Term Tubes
 EF= Exhaust Fan; PF = Pit Fan

FIGURE 4.1 - SCHEMATIC OF GAS MONITORING AT FARM SITE 4, VISIT NUMBER 1.

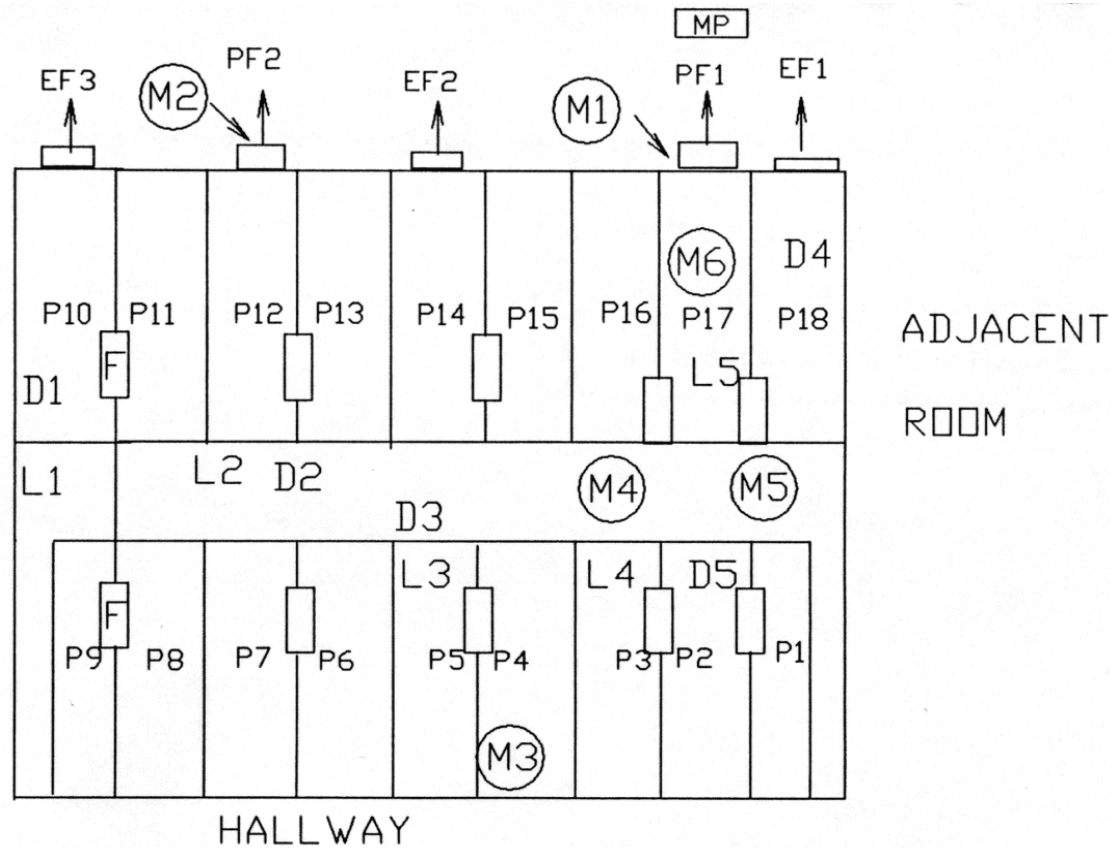

Date of Visit: 90-10-05
 Barn Size: 36 ft x 90 ft.
 P = Pen; MP = Manure Pump
 F = Feeder; PP = Pumping Port

M = H₂S, Continuous Monitoring Location
 D = NH₃, CO₂, H₂S Diffusion Tubes
 L = NH₃, CO₂, H₂S Long-Term Tubes
 EF = Exhaust Fan; PF = Pit Fan

FIGURE 4.2 - SCHEMATIC OF GAS MONITORING AT FARM SITE 4, VISIT NUMBER 2.

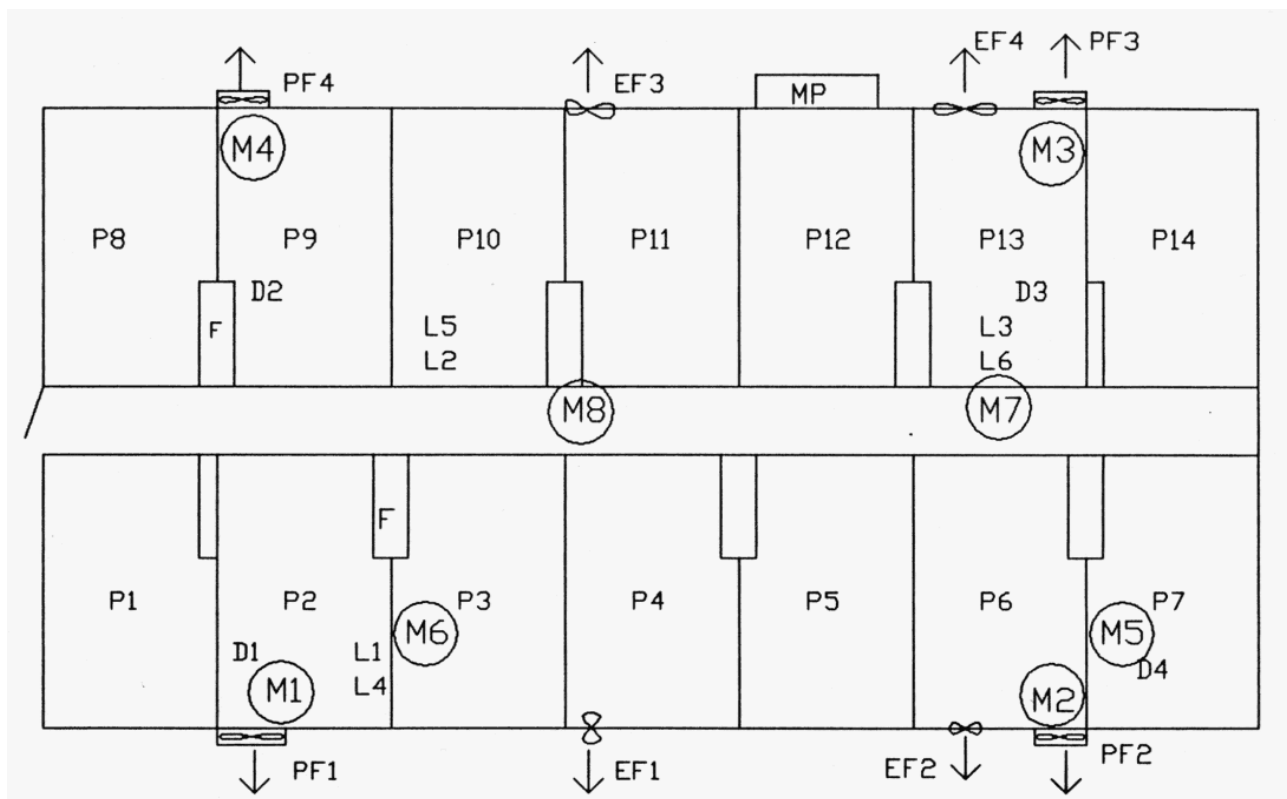

Date of Visit: 90-10-03
 Barn Size: 36 ft x 70 ft.
 P = Pen; MP = Manure Pump
 F = Feeder; PP = Pumping Port

M = H₂S, Continuous Monitoring Location
 D = NH₃, CO₂, H₂S Diffusion Tubes
 L = NH₃, CO₂, H₂S Long-Term Tubes
 EF= Exhaust Fan; PF = Pit Fan

FIGURE 5.1 - SCHEMATIC OF GAS MONITORING AT FARM SITE 5, VISIT NUMBER 1.

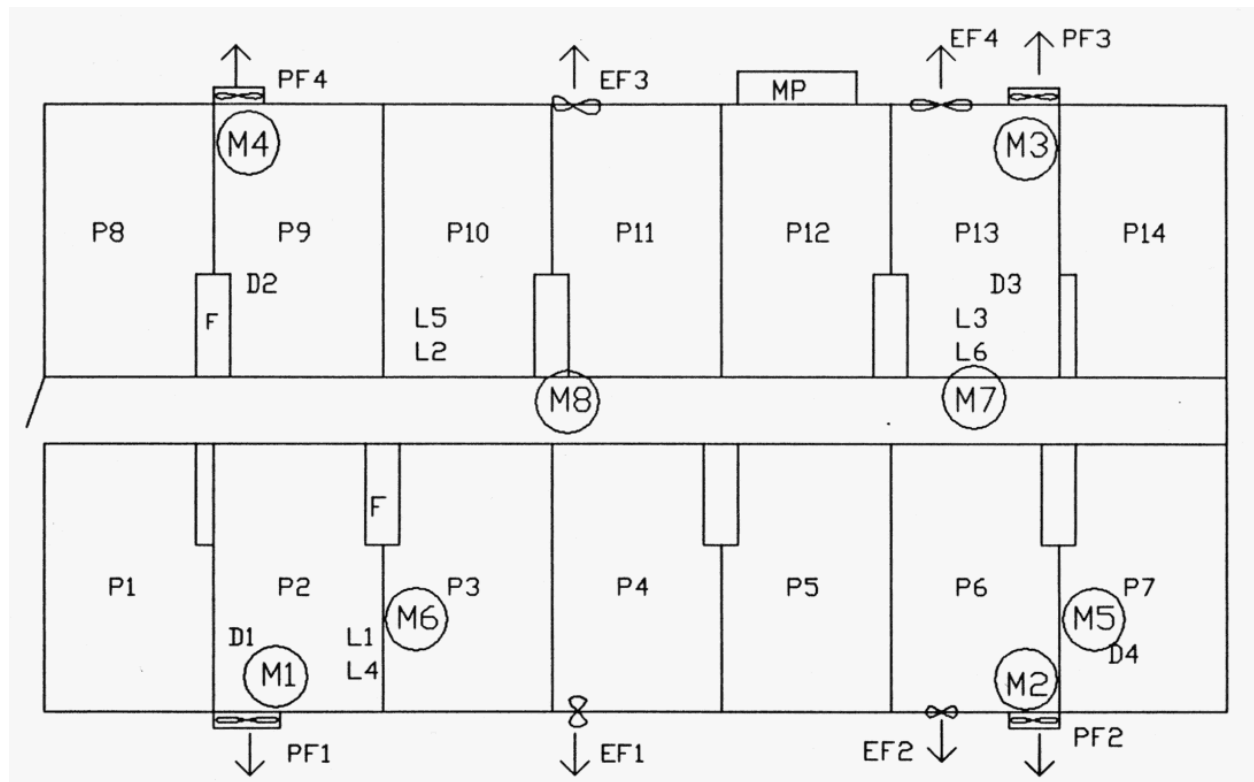

Date of Visit: 91-05-08
 Barn Size: 36 ft x 70 ft
 P = Pen; MP = Manure Pump
 F = Feeder; PP = Pumping Port

M = H₂S, Continuous Monitoring Location
 D = NH₃, CO₂, H₂S Diffusion Tubes
 L = NH₃, CO₂, H₂S Long-Term Tubes
 EF= Exhaust Fan; PF = Pit Fan

FIGURE 5.2 - SCHEMATIC OF GAS MONITORING AT FARM SITE 5, VISIT NUMBER 2.

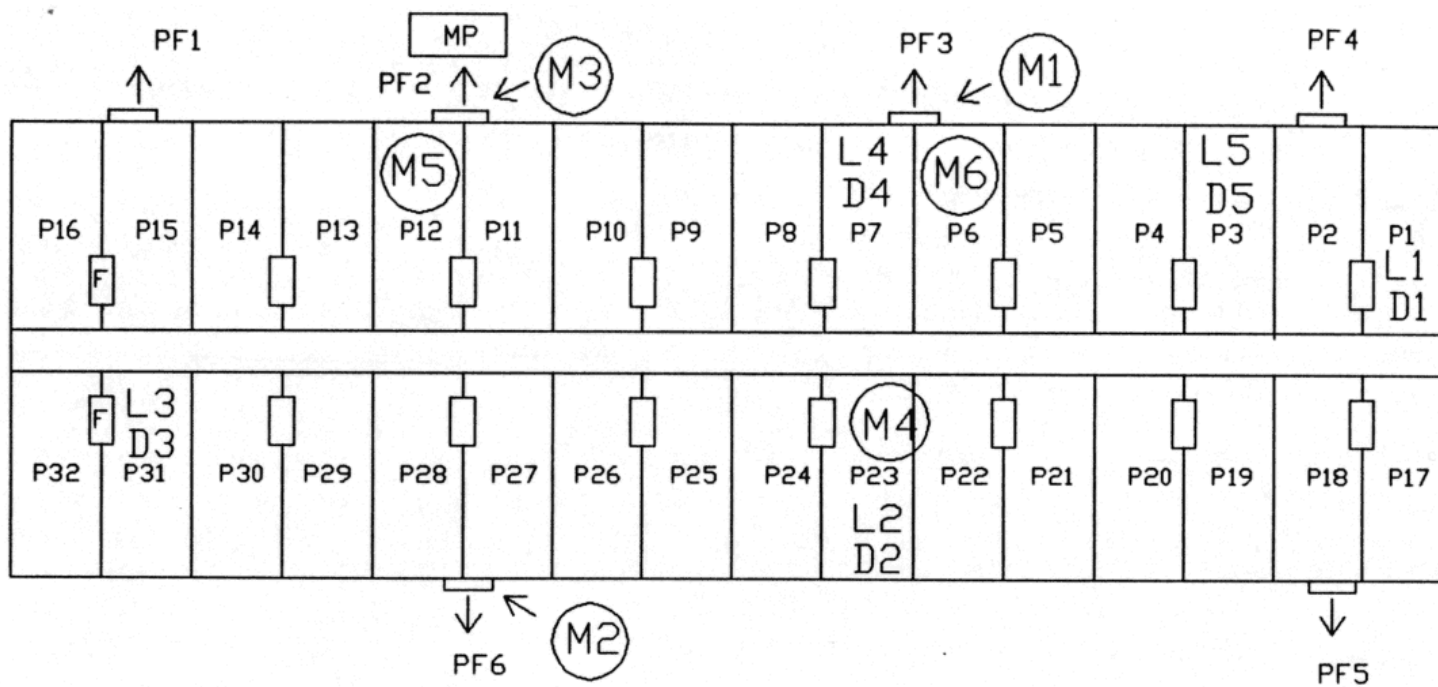

Date of Visit: 90-10-04
 Barn Size: 36 ft x 120 ft.
 P = Pen; MP = Manure Pump
 F = Feeder; PP = Pumping Port

M = H₂S, Continuous Monitoring Location
 D = NH₃, CO₂, H₂S Diffusion Tubes
 L = NH₃, CO₂, H₂S Long-Term Tubes
 EF= Exhaust Fan; PF = Pit Fan

FIGURE 6.1 - SCHEMATIC OF GAS MONITORING AT FARM SITE 6, VISIT NUMBER 1.

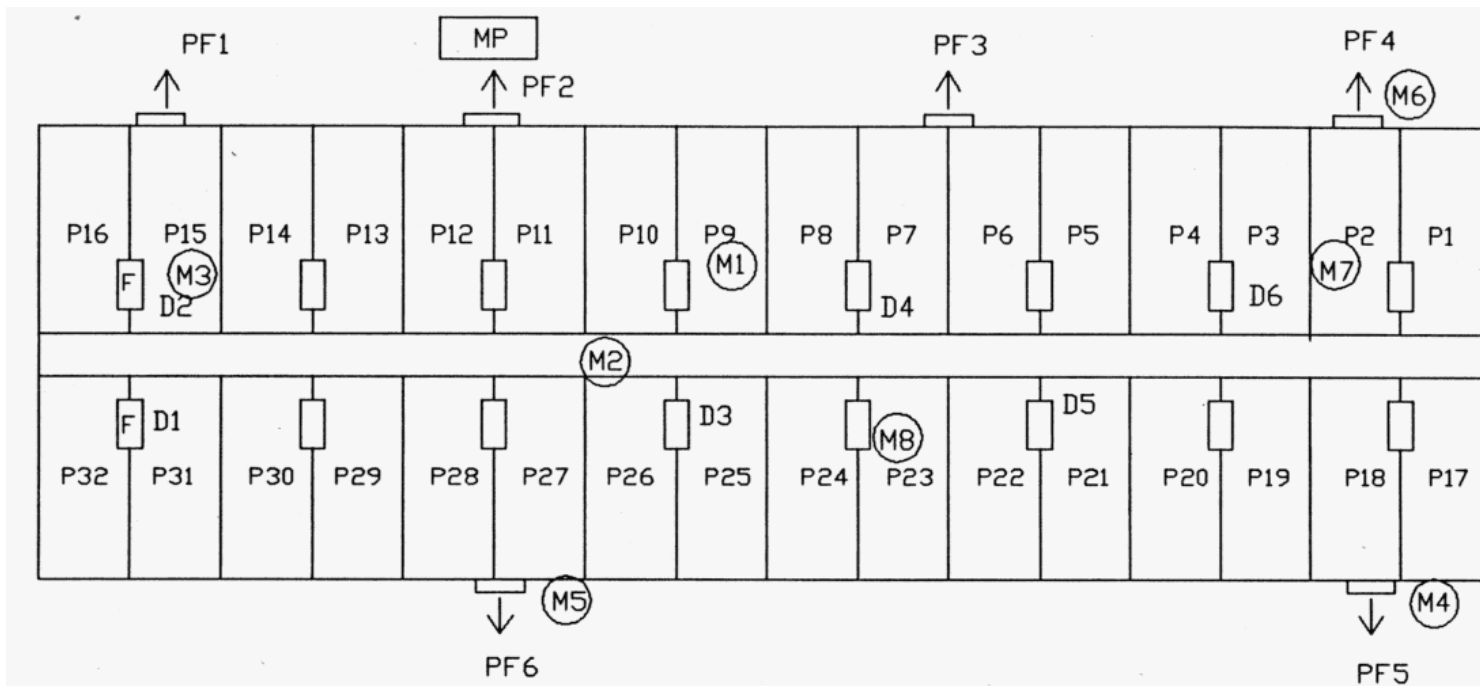

Date of Visit: 91-05-10
 Barn Size: 36 ft x 120 ft.
 P = Pen; MP = Manure Pump
 F = Feeder; PP = Pumping Port

M = H₂S, Continuous Monitoring Location
 D = NH₃, CO₂, H₂S Diffusion Tubes
 L = NH₃, CO₂, H₂S Long-Term Tubes
 EF= Exhaust Fan: PF = Pit Fan

FIGURE 6.2 - SCHEMATIC OF GAS MONITORING AT FARM SITE 6, VISIT NUMBER 2.

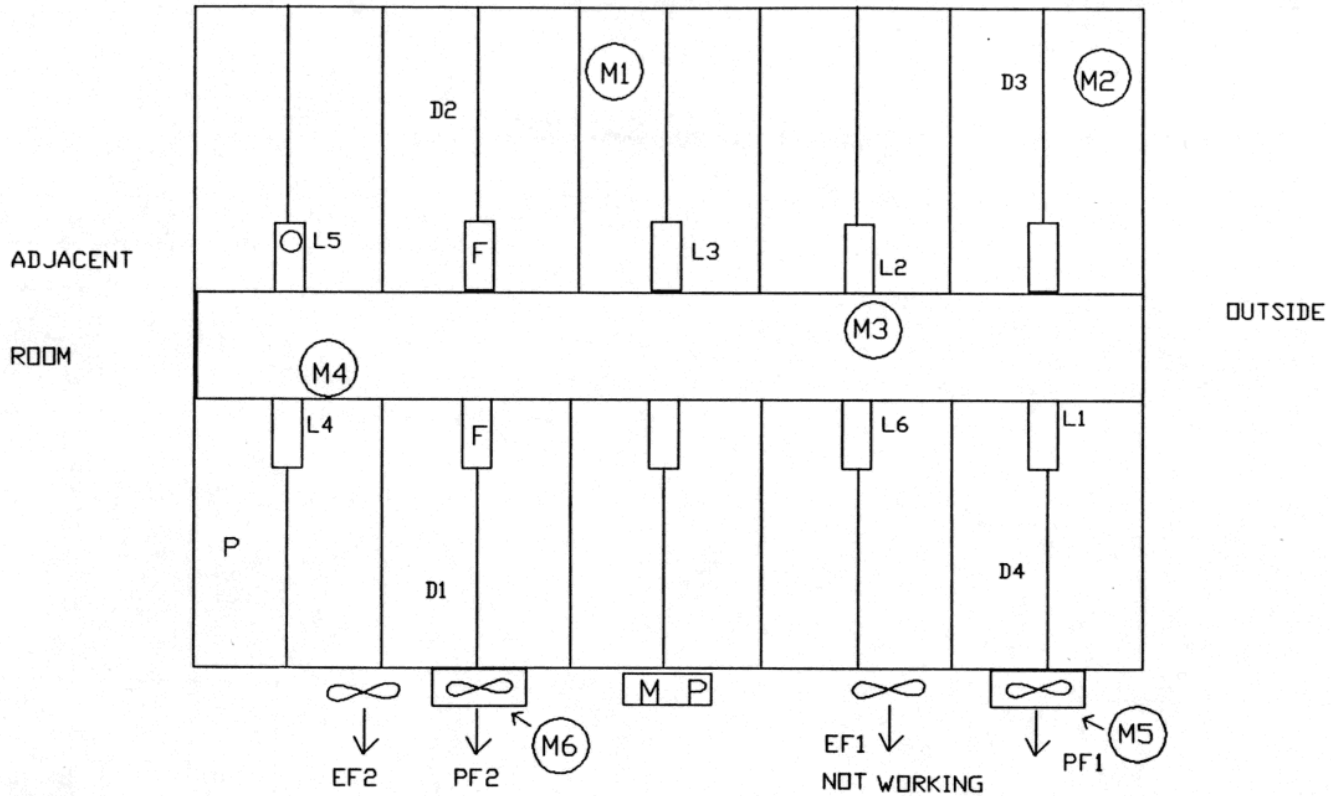

Date of Visit: 91-05-09
 Barn Size: 40 ft x 70 ft.
 P = Pen; MP = Manure Pump
 F = Feeder; PP = Pumping Port

M = H₂S, Continuous Monitoring Location
 D = NH₃, CO₂, H₂S Diffusion Tubes
 L = NH₃, CO₂, H₂S Long-Term Tubes
 EF = Exhaust Fan; PF = Pit Fan

FIGURE 7.0 - SCHEMATIC OF GAS MONITORING AT FARM SITE 7,

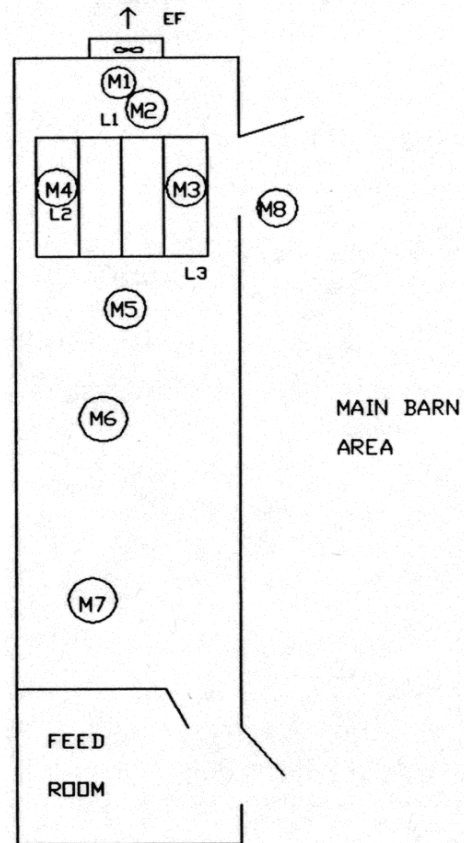

Date of Visit: 91-05-07
 Barn Size: 14 ft x 30 ft.
 P = Pen; MP = Manure Pump
 F = Feeder; PP = Pumping Port

M = H₂S, Continuous Monitoring Location
 D = NH₃, CO₂, H₂S Diffusion Tubes
 L = NH₃, CO₂, H₂S Long-Term Tubes
 EF= Exhaust Fan; PF = Pit Fan

FIGURE 8.1 - SCHEMATIC OF GAS MONITORING AT FARM SITE 8, VISIT NUMBER 1.

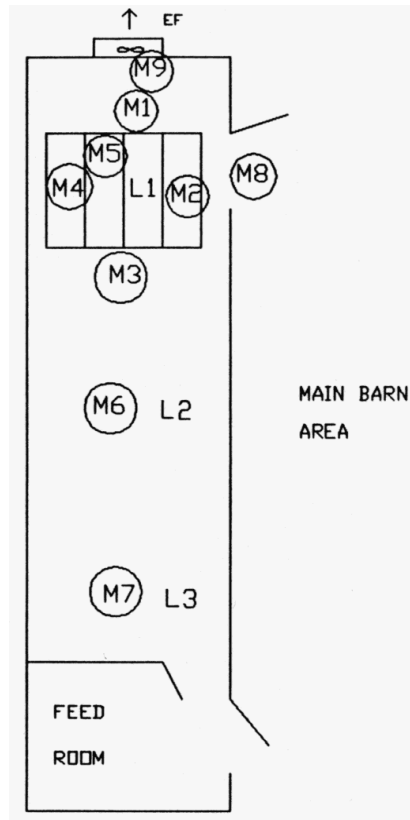

Date of Visit: 91-10-18
 Barn Size: 14 ft x 30 ft.
 P = Pen; MP = Manure Pump
 F = Feeder; PP = Pumping Port

M = H₂S, Continuous Monitoring Location
 D = NH₃, CO₂, H₂S Diffusion Tubes
 L = NH₃, CO₂, H₂S Long-Term Tubes
 EF= Exhaust Fan; PF = Pit Fan

FIGURE 8.2 - SCHEMATIC OF GAS MONITORING AT FARM SITE 8, VISIT NUMBER 2.

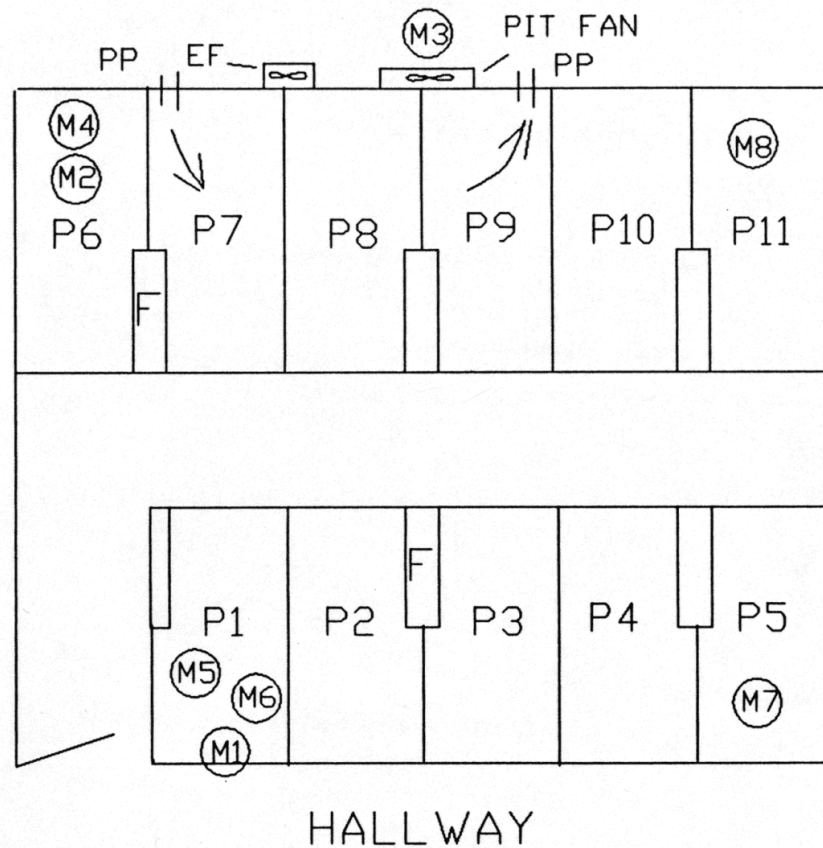

Date of Visit: 91-05-28
 Barn Size: 25 ft x 30 ft.
 P = Pen; MP = Manure Pump
 F = Feeder; PP = Pumping Port

M = H₂S, Continuous Monitoring Location
 D = NH₃, CO₂, H₂S Diffusion Tube
 L = NH₃, CO₂, H₂S Long-Term Tubes
 EF= Exhaust Fan; PF = Pit Fan

FIGURE 9.0 - SCHEMATIC OF GAS MONITORING AT FARM SITE 9,

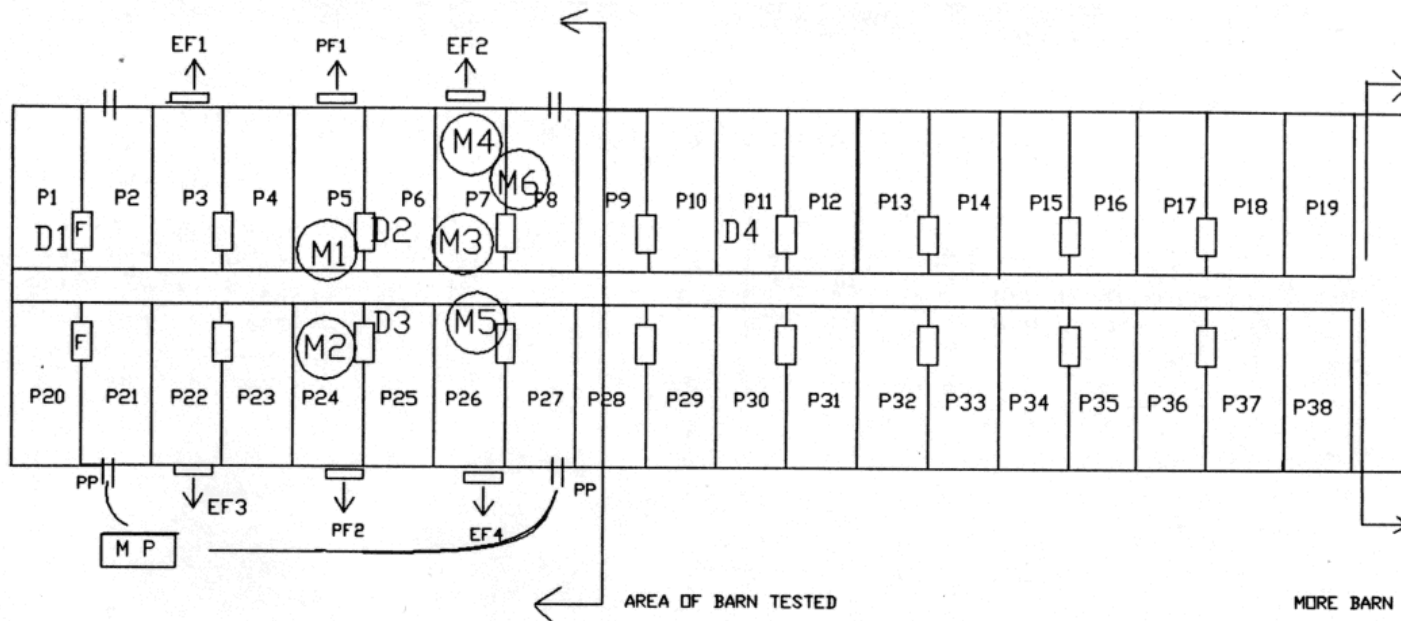

Date of Visit: 91-05-28
 Barn Size: 36 ft x 170 ft.
 P = Pen; MP = Manure Pump
 F = Feeder; PP = Pumping Port

M = H₂S, Continuous Monitoring Location
 D = NH₃, CO₂, H₂S Diffusion Tube
 L = NH₃, CO₂, H₂S Long-Term Tubes
 EF= Exhaust Fan; PF = Pit Fan

FIGURE 10.0 - SCHEMATIC OF GAS MONITORING AT FARM SITE 10,

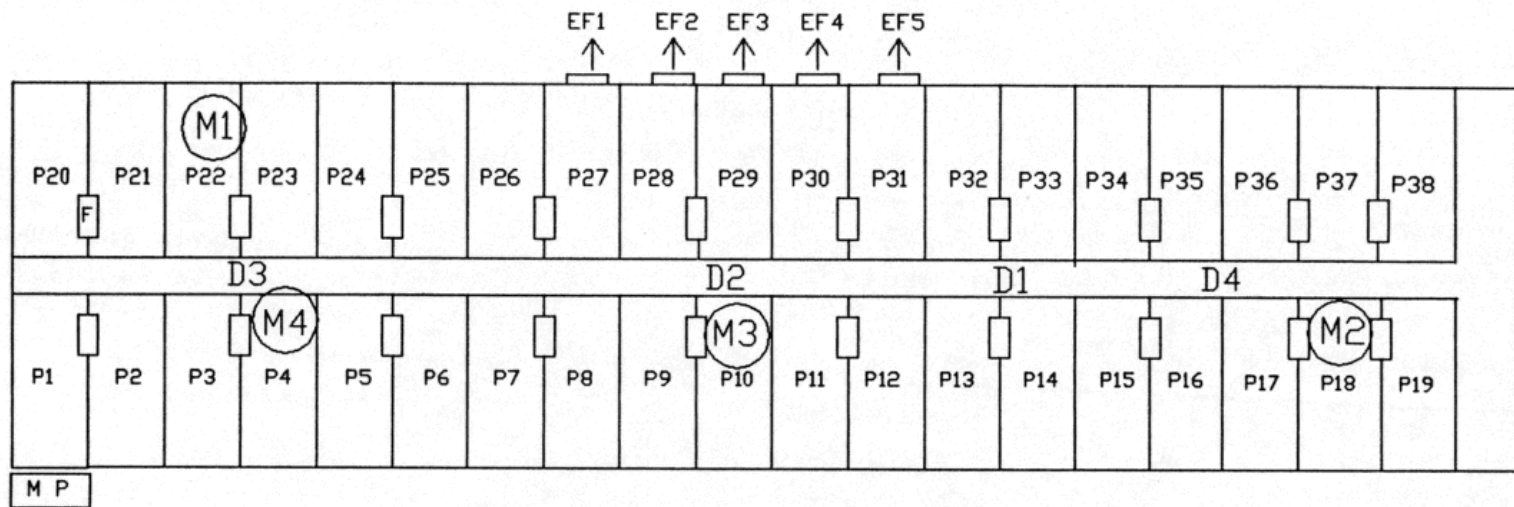

Date of Visit: 89-11-24
 Barn Size: 36 ft x 70 ft.
 P = Pen; MP = Manure Pump
 F = Feeder; PP = Pumping Port

M = H₂S, Continuous Monitoring Location
 D = NH₃, CO₂, H₂S Diffusion Tube
 L = NH₃, CO₂, H₂S Long-Term Tubes
 EF= Exhaust Fan; PF = Pit Fan

FIGURE 11.0 - SCHEMATIC OF GAS MONITORING AT FARM SITE 11,

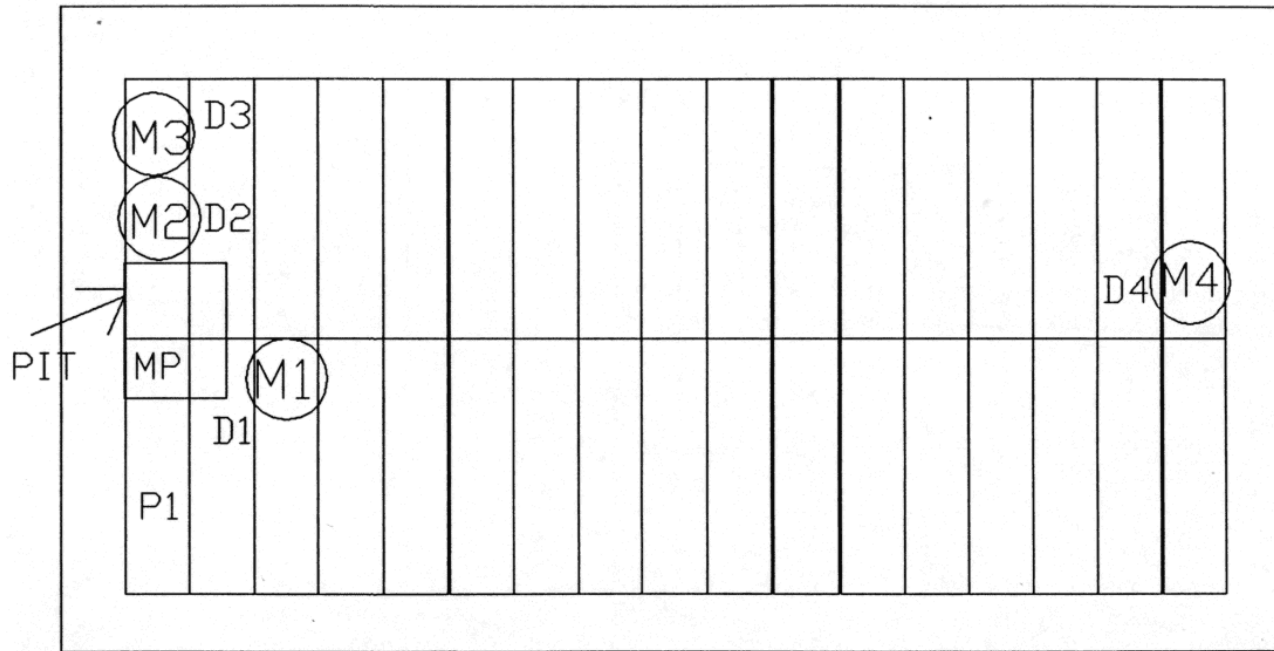

Date of Visit: 89-12-7
 Barn Size: 56 ft x 125 ft.
 P = Pen; MP = Manure Pump
 F = Feeder; PP = Pumping Port

M = H₂S, Continuous Monitoring Location
 D = NH₃, CO₂, H₂S Diffusion Tube
 L = NH₃, CO₂, H₂S Long-Term Tubes
 EF= Exhaust Fan; PF = Pit Fan

FIGURE 12.0 - SCHEMATIC OF GAS MONITORING AT FARM SITE 12,

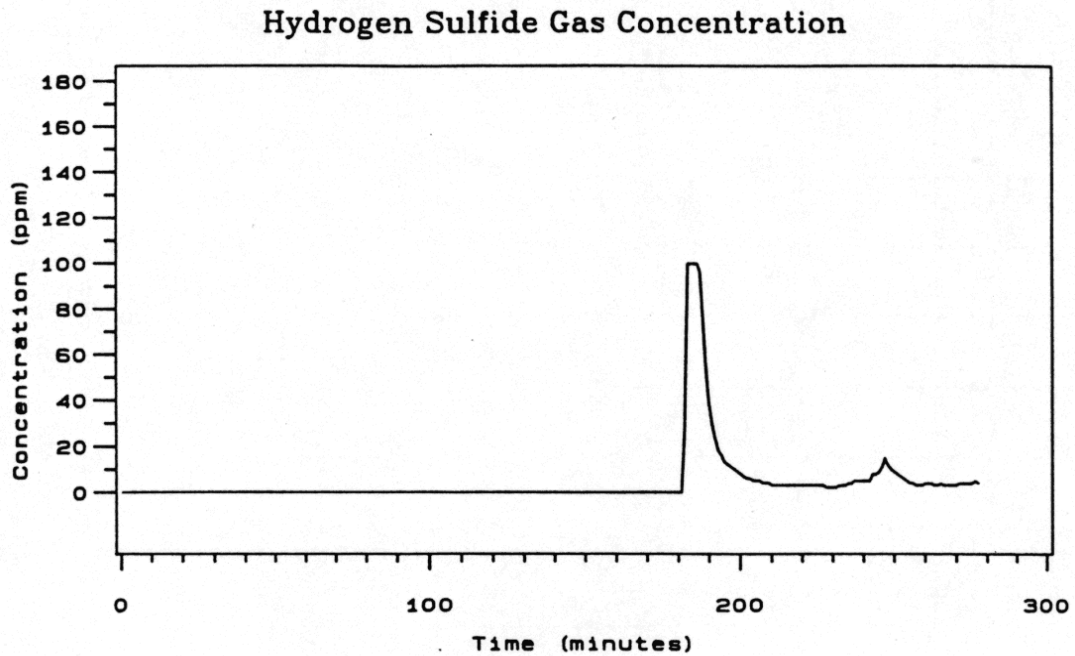

FIGURE 13 Concentration of H₂S Gas in Barn Air at Feeder Level, Site M4, Figure 3.1. These measurements correspond to those in Figure 15, Pit Exhaust Air.

Note:

1. The concentration in the barn air was negligible prior to mixing and it was consistently much less than in the pit exhaust air.
2. The rapid rise in gas concentration at minute 180 was caused by momentary exposure of nozzle above the slurry surface.

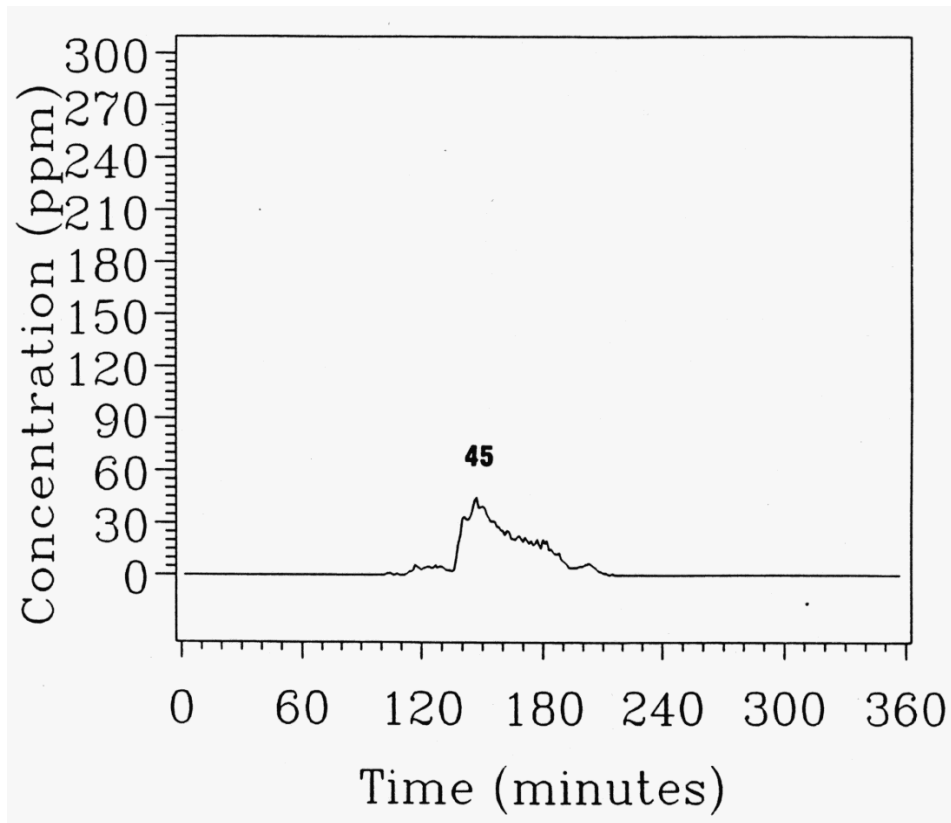

FIGURE 14 Concentration of H₂S in Barn Air at Floor Level, Site M4, Figure 5.1. These measurements correspond to those in Figure 19, Pit Exhaust Air.

Note:

1. The concentration in the barn air was negligible prior to start of mixing (at minute 60) and that it was consistently much less than in the pit exhaust air.

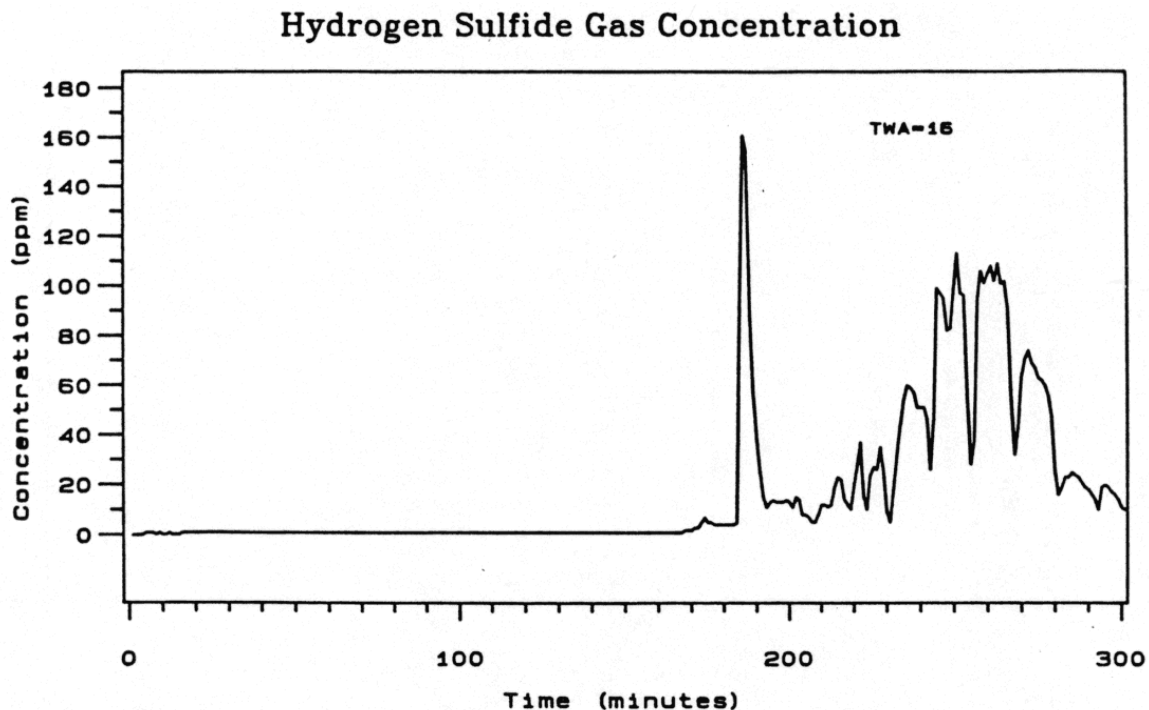

FIGURE 15 Concentration of H₂S Gas in Manure Pit Exhaust Air at Site M5, Figure 3.1. Nozzle was directed at Site M5. Corresponding concentrations in pit exhaust air at Site M1 were less than those at Site M5.

Note:

1. Concentration was zero until circulation pump was started at minute 160.
2. The rapid rise in concentration at minute 180 was caused by momentary exposure of nozzle above slurry surface.
3. Peaks and valleys in concentration were caused by filling of tankers.
4. Gradual increase in concentration was followed by gradual decrease during mixing.
5. The TWA was only 16 ppm even though the concentration exceeded 100 ppm for several minutes.

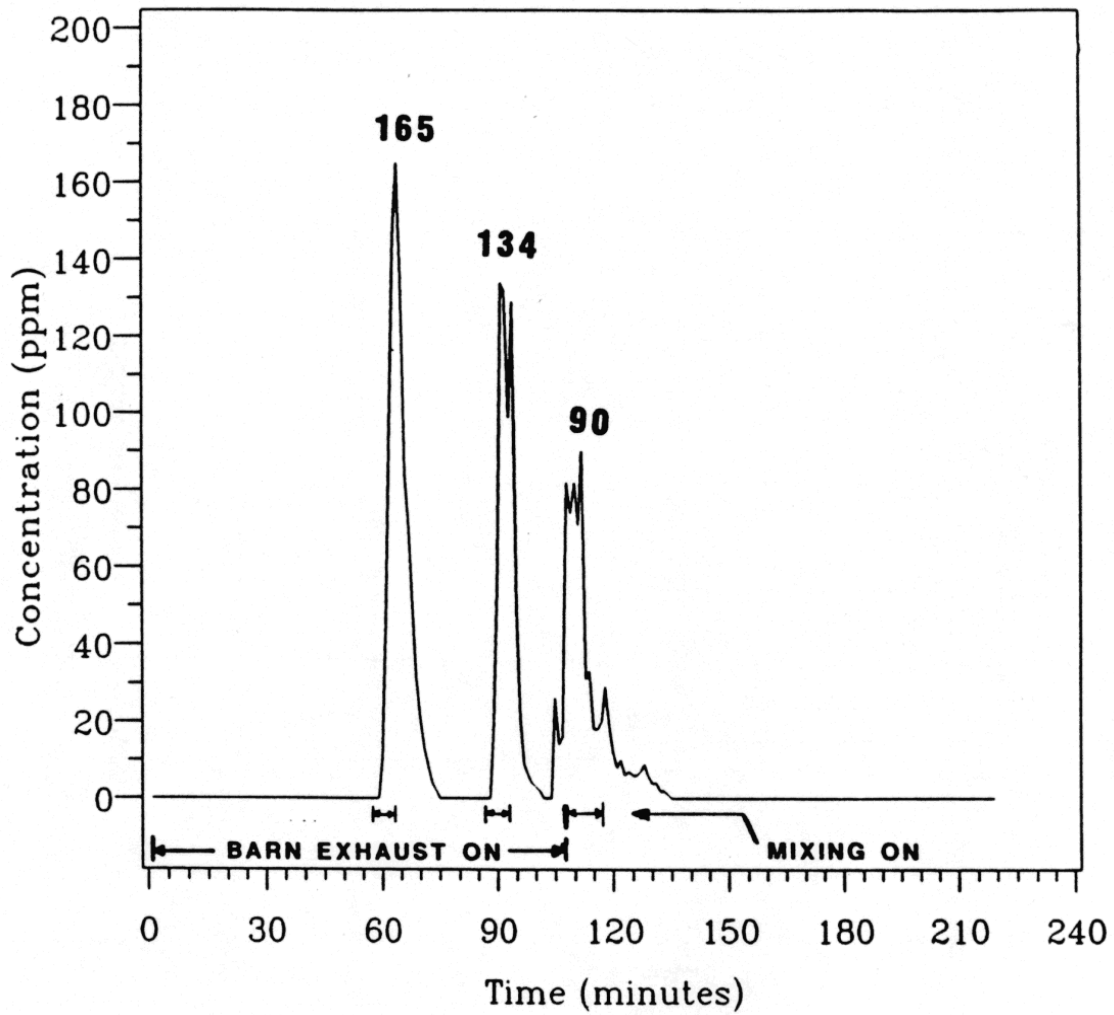

FIGURE 16 Concentration of H₂S Gas in Barn Air at Floor Level at Site M4, Figure 7. These measurements correspond to those in Figure 18.

Note:

1. The immediate and rapid increase in concentration during mixing periods.
2. High gas concentration inside the barn when barn exhaust fans were on compared to when they were off.

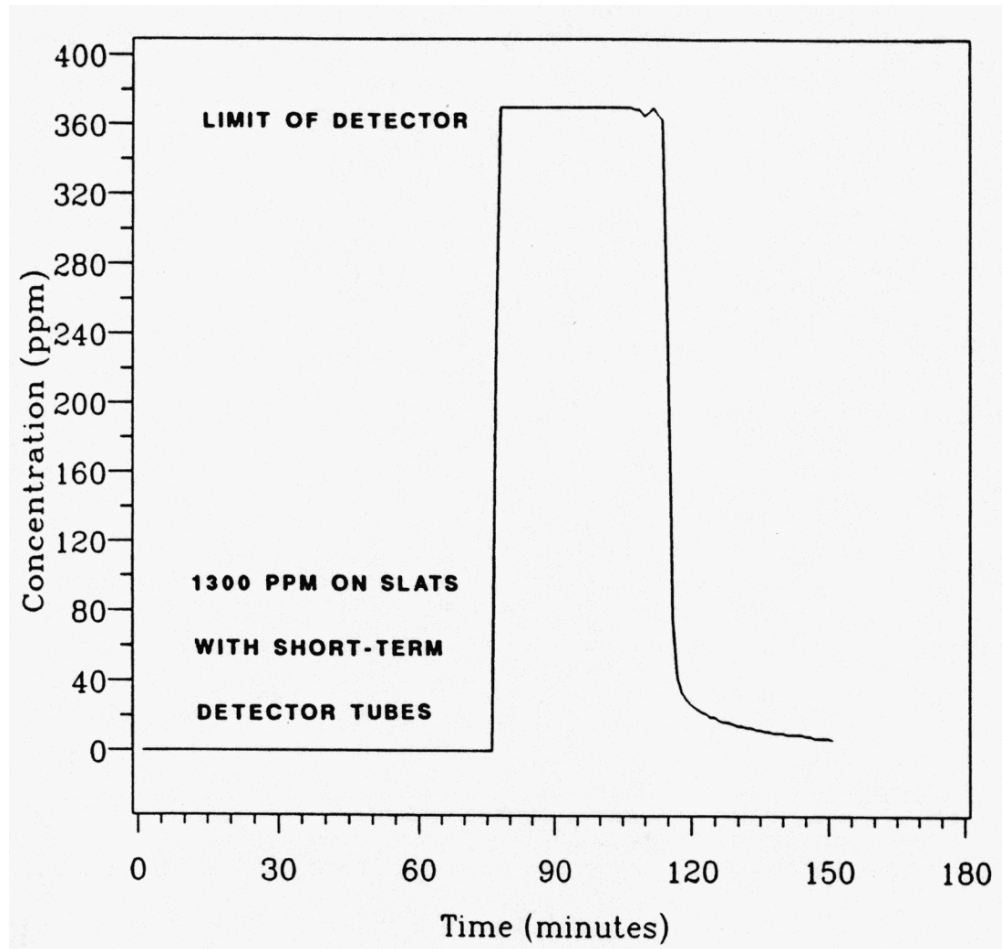

FIGURE 17. Concentration of H₂S Gas in Barn Air on Slats at Site M3, Figure 8.1.

Note:

1. Mixing was by bubbling air in slurry.
2. Instantaneous rise in H₂S concentration to very high levels occurred as soon as mixing started at minute 75.
3. The concentration averaged 1100 ppm during the 35 minute period after agitation started.
4. The rapid decrease in concentration occurred when mixing was stopped at minute 112.

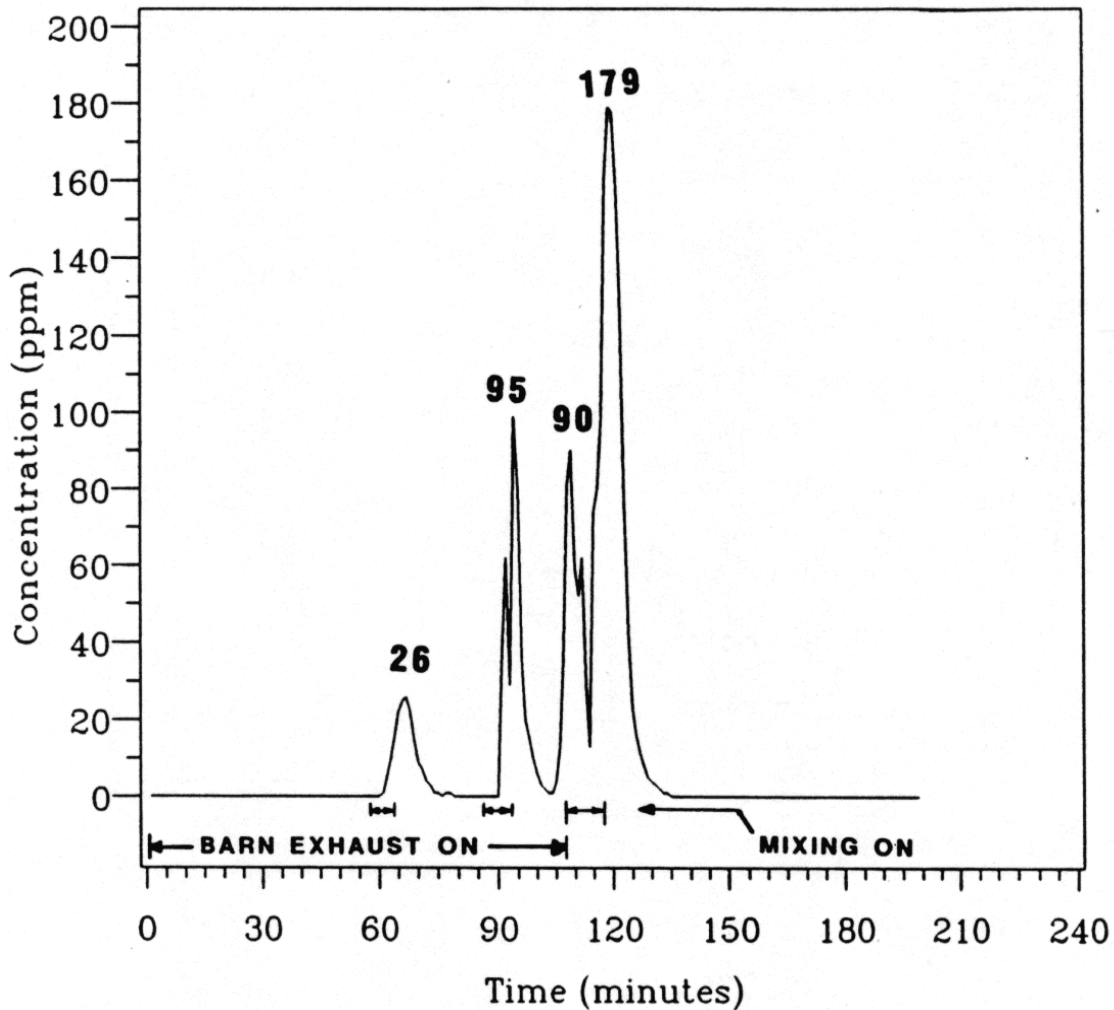

FIGURE 18 Concentration of H₂S Gas in Manure Pit Exhaust Air at Site M5, Figure 7. These measurements correspond to those in Figure 16.

Note:

1. Low concentration in pit fan exhaust air when barn exhaust fans were on compared to when they were off.
2. Peak concentrations were lower in pit exhaust than on barn floor while barn exhaust fans were on (see Figure 16).

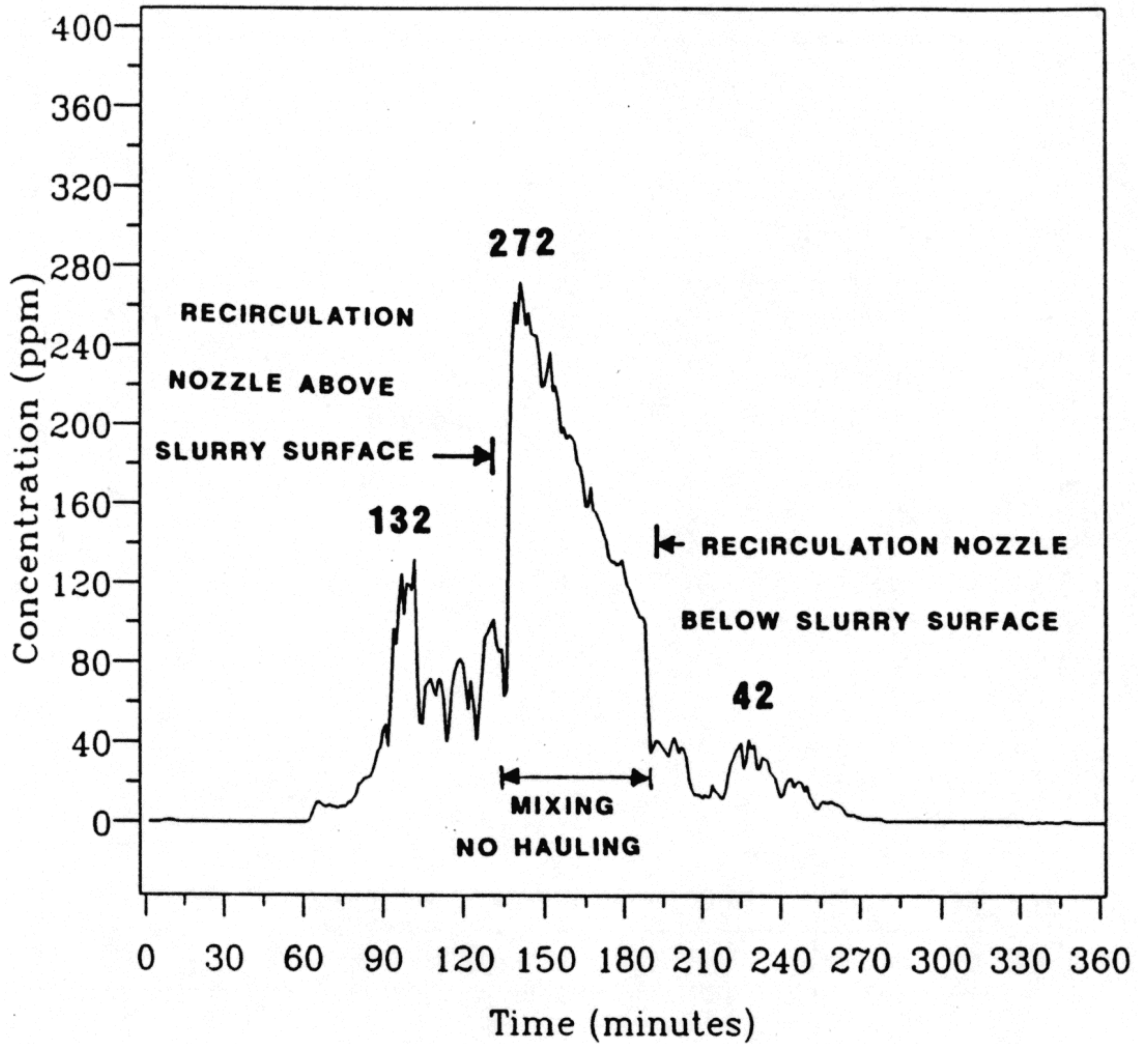

FIGURE 19 Concentration of H₂S Gas in Manure Pit Exhaust Air at Site M1, Figure 5.1.

Note:

1. Concentration was zero until circulation pump was started at minute 60.
2. A rapid rise in concentration occurred when nozzle became exposed, and a rapid fall in concentration when nozzle was resubmerged.
3. Slow decrease in concentration as mixing progressed.

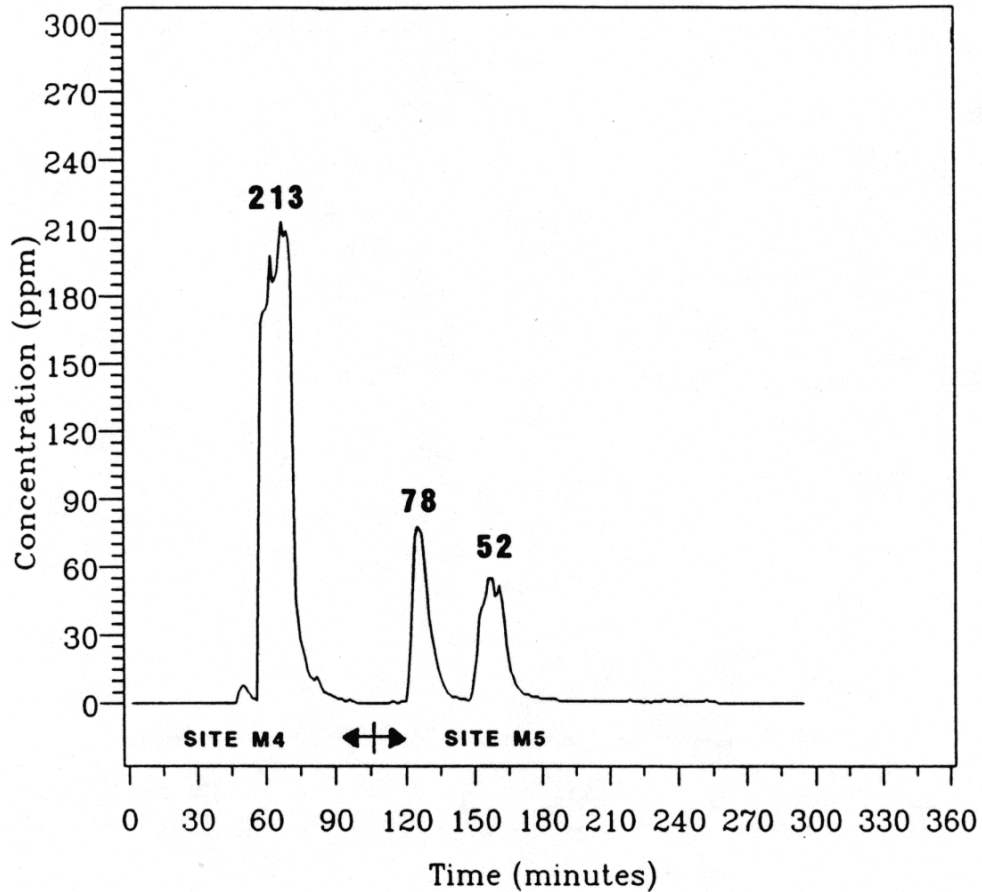

FIGURE 20 Concentration of H₂S Gas in Barn Air at Floor Level at Sites M4 and M5, Figure 6.1. Gas monitor was moved from Site M4 to Site M5 at minute 115.

Note:

1. Pit Fan PF5 was not functioning.
2. The peak of 213 ppm in barn air at slat level corresponded to a peak of 262 ppm that was observed at the same moment in pit exhaust air at PF6.
3. It appears that non-functioning pit fan at PF5 caused the high concentration of 213 ppm.
4. Concentrations at floor level at Site M5 near the functioning pit fan PF2 were much lower than at Site M4.