

TRANSIENT HAZARDOUS CONDITIONS IN ANIMAL BUILDINGS DUE TO MANURE GAS RELEASED DURING SLURRY MIXING

N. K. Patni, S. P. Clarke

MEMBER
ASAE

ABSTRACT

Concentrations of hydrogen sulfide (H_2S), ammonia (NH_3), carbon dioxide (CO_2), and methane (CH_4) were monitored during mixing of slurry in subfloor manure storage pits in dairy-cattle, swine, and caged-layer barns. Transient short-term high concentrations of H_2S indicated the potential for hazardous conditions inside barns during slurry mixing. Because of this, time-weighted average concentrations of H_2S are of little value in terms of gas hazard indication. The degree of manure slurry turbulence and its splashing in pit free space may be the dominant factor in the control of rapid release of H_2S and its high concentration compared to other factors such as animal diet and species, ventilation conditions, etc. For operator and animal safety, it is highly desirable to use a submerged recirculation pipe for mixing slurry in subfloor pits in animal buildings and to prevent free-falling or splashing of manure, or blowing of air into manure. Remote warning devices to indicate failure of pit exhaust fans would also be very useful for taking rapid remedial action against high H_2S concentration inside the barn, such as shutting off manure pump(s). **KEYWORDS.** Slurry, Manure gas, Mixing, Hydrogen sulfide (H_2S).

INTRODUCTION

A number of different gases and volatile compounds are formed due to anaerobic biodegradation of manure slurry during storage prior to disposal. At least 77 volatile compounds and gases associated with swine manure have been identified (Miner, 1981). Of the gases produced, hydrogen sulfide (H_2S), ammonia (NH_3), carbon dioxide (CO_2), and methane (CH_4) are the most important because of the large quantities in which they are released, and the potential hazards that they can create. In spite of the well-known dangers of manure gases since the sixties (O'Donoghue, 1961; McAllister and McQuitty, 1965; Noren et al., 1967; Taiganides and White, 1969), reports of fatalities or near-fatalities keep appearing (Simensen, 1987; Bodus, 1987; Anonymous, 1986, 1982; Dirksen and Dahme, 1983; Donham et al., 1982; Feilden, 1982; Langer, 1982). Most of the accidents occurred during mixing and agitation of slurry that was held indoors or in external storage pits from which

manure gases backed into the barns. It is noteworthy that accidents, including fatalities, sometimes occurred under operational procedures and ventilation conditions which had often been used before without problems. Subsequent measurements of gas concentrations under conditions similar to those under which the accidents occurred indicated non-lethal concentrations.

Although the particular gas or gases which caused the fatalities or injuries were never identified, H_2S is generally presumed to be the cause. Lethal concentrations of NH_3 , CO_2 , and CH_4 are not usually associated with slurry handling. In the past, gas concentration determinations in animal buildings have usually been made using gas detection tubes on site, or by pumping air samples to remotely located (e.g., in a mobile unit outside the barns) gas detection instruments. Such systems have the disadvantage that the measured concentrations are short-term values or time-weighted averages, or are sequential rather than continuous when several sites in a building are monitored simultaneously. Short-term gas concentration increases may go undetected in such systems.

The objective of this study was to determine H_2S concentrations continuously and simultaneously at several sites in animal buildings to determine the transient nature of hazardous conditions during mixing of slurry that had been stored for some time. A secondary objective was to determine concentrations of NH_3 , CO_2 , and CH_4 at the same time using detector tubes.

STUDY PROCEDURE

GAS CONCENTRATION MEASUREMENT SITES AND CONDITIONS

All gas concentration measurements were made on the day of slurry mixing, prior to, during, and immediately following the mixing operation. Concentrations were measured under normal ventilation conditions in a freestall slotted floor dairy cattle barn (summer and winter), in a slotted-floor heifer barn (winter), in three growing-finishing swine barns (autumn and spring), and in two caged-layer barns (winter). Unless indicated otherwise, the pits were full at the time of mixing.

The 240-cow, free-stall, dairy cattle barn had eight long pits or trenches, each 29.2 x 2.3 x 1.3 m deep, with about 30 cows above each pit (fig. 1). The heifer barn had four long pits or trenches, each 24.0 x 4.6 x 1.3 m deep, with about 60 heifers above each pit. These long pits were fitted with a sluice gate at one end and a nozzle with a guillotine valve at the opposite end. Manure accumulated in the pits for five weeks at the end of which it was mixed by recirculation as described by

Article was submitted for publication in September 1990; reviewed and approved for publication by the Structures and Environment Div. of ASAE in March 1991.

Contribution No. 1701 from Animal Research Centre.

The authors are N. K. Patni, Research Scientist, Animal Research Centre, Agriculture Canada, Ottawa, Ontario, Canada; and S. P. Clarke, Extension Agricultural Engineer, Ontario Ministry of Agriculture and Food, Nepean, Ontario, Canada.

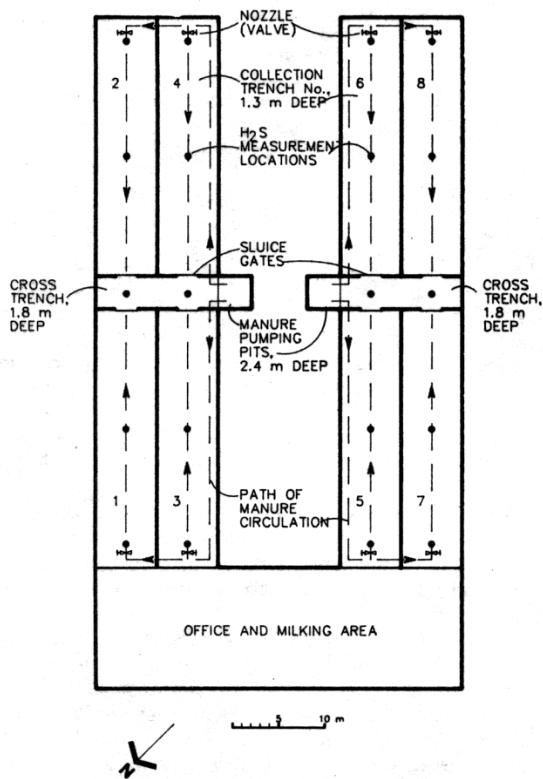

Figure 1— Layout of the 240-cow barn used for manure gas concentration measurement during slurry mixing.

Turnbull et al. (1971). Gas concentrations were measured at the floor level near the sluice gate, the recirculation nozzle, and mid-way along the length in each of the pits (fig. 1). The operational conditions and procedures did not vary from pit to pit in the barns. The manure contained 7 to 9% total solids by weight, and had a pH of about 6.7.

The three, fully slotted floor, swine barns (A, B, and C) had 3.0 m deep pits under the slats with associated pit exhaust ducts and fans. Gas concentrations were measured in the pit exhaust air, and inside the barn at three to six locations at the floor level or about 1.0 m above the floor in all three barns. Only H₂S concentration was measured in the pit exhaust air.

In barn A, manure in the 19.2 x 12.2 m pit was mixed by recirculation using an external centrifugal pump connected to a suction pipe and a submerged discharge pipe. In barn B (fig. 2), manure in the 16.8 x 15.2 m pit was mixed using a submerged centrifugal pump in a pit opening outside the barn. Manure depth in the pits was 1.5 m in both barns A and B at the time of mixing, when the barn ventilation fans were shut off and only the pit fans were operated at maximum speed. The mixing operation was interrupted periodically to fill tankers for hauling manure to the fields. Prior to mixing, the manure total solids content was 0.8 and 2.4% at the 0.6 m depth, and 6.4 and 5.6% at the 1.2 m depth below the manure surface in barns A and B, respectively. Manure pH ranged from 7.3 to 7.8. Barn C had a 26.9 x 11.0 m room above two manure pits (12.0 x 12.6 m and 14.9 x 12.6 m), each with its own pit exhaust duct.

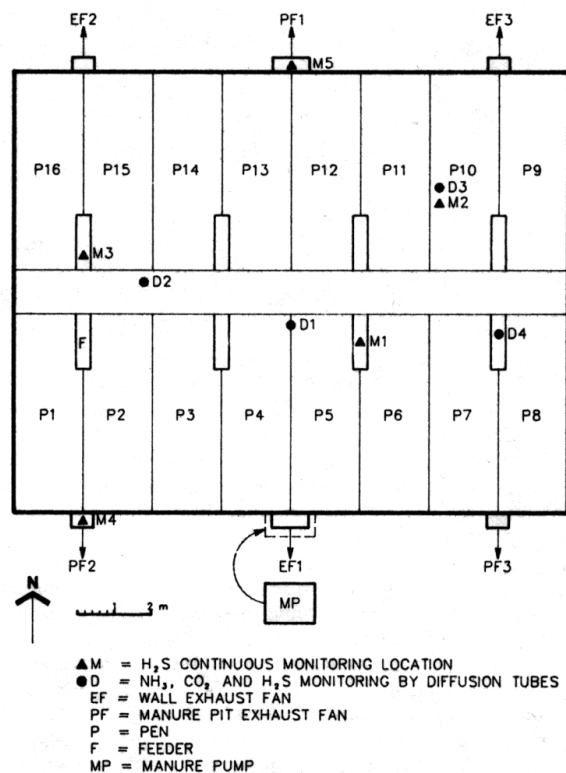

Figure 2— Layout of swine barn B used for manure gas concentration measurement during slurry mixing.

The pits were full on the day of gas measurement. The level in the 12.0 x 12.6 m pit was lowered by 0.3 m using a truck-mounted vacuum tanker to haul the slurry. Further hauling by the custom hauler was suspended for the rest of the day because of rain and wet conditions. Prior to his departure, the custom hauler mixed the manure in the pit for a few minutes by blowing air into the bottom of the pit using the vacuum tanker. H₂S concentration changes could be determined during mixing of slurry by this method. Manure solids content at 0.9 m depth in the pit was 0.5% and the pH was 7.4.

The two caged-layer barns had manure gutters or trenches (27.6 x 1.2 x 0.4 m deep) beneath suspended cage batteries. Manure in the gutters was mechanically scraped every day to slide-gate-equipped hatch openings at the end of the gutters where it dropped into 7.2 x 2.7 x 2.0 m deep pits. The manure was mixed using a submersible centrifugal pump through an external pit opening. During mixing, the slide-gate covers on the hatches were closed and H₂S concentration was measured just below and above the hatch covers. Concentrations of other gases were measured at four locations in these barns, 0.2, 0.8, 0.8, and 1.9 m above the floor. The manure solids content in the pits was 9.7 to 11.6 % by weight. Manure pH ranged from 7.0 to 7.4.

GAS CONCENTRATION MEASUREMENT EQUIPMENT

One-minute average concentrations of H₂S were monitored at up to six different locations using electrochemical

cell H₂S sensors and associated dataloggers made by Compur-Electronic GmbH, Munich, Germany, and/or National Draeger Inc., Pittsburgh, Pennsylvania, U.S.A. The nominal detection limit of the H₂S sensors was 100 and 200 ppm for the Compur and Draeger units, respectively. The sensor cells were calibrated prior to each use. The calibration was verified after the measurements using standard H₂S/air mixtures produced by blending of a standard H₂S/nitrogen mixture with different proportions of air using mass flow controllers (Matheson Gas Co., Whitby, Ontario). Draeger long-term and diffusion-type gas detector tubes were used to determine time-weighted average concentrations of NH₃, CO₂, and H₂S. Draeger Polymer peristaltic pumps were used with the long-term tubes. Draeger short-term detector tubes and bellows pumps were used for spot checks of H₂S, NH₃, CO₂, and CH₄ gases.

RESULTS AND DISCUSSION

At present there are no standard or guideline values for acceptable or non-acceptable gas concentrations in confined animal buildings. The American Conference of Governmental Industrial Hygienists (ACGIH, 1983) specifies the following three categories of Threshold Limit Values (TLVs[®]) for gas concentrations for human exposure to gases and vapors:

1. Threshold Limit Value-Time Weighted Average (TLV-TWA). The time-weighted average concentration for a normal 8-hour workday and a 40-hour work week to which nearly all workers may be repeatedly exposed, day after day, without adverse effect.

2. Threshold Limit Value-Short Term Exposure Limit (TLV-STEL). The maximum concentration to which workers can be exposed for a period up to 15 min continuously without suffering from 1) irritation, 2) chronic or irreversible tissue change, or 3) narcosis of sufficient degree to increase accident proneness, impair self-rescue, or materially reduce work efficiency, provided that no more than four excursions per day are permitted, with at least 60 minutes between exposure periods, and provided that the daily TLV-TWA also is not exceeded. The STEL should be considered a maximal allowable concentration, or ceiling, not to be exceeded at any time during the 15-min excursion period.

3. Threshold Limit Value-Ceiling (TLV-C). The concentration that should not be exceeded even instantaneously. The TLVs and other characteristics of the main manure gases are given in Table 1 (ACGIH, 1983; Agriculture Canada, 1979). There are no specified TLV-C values for H₂S, NH₃, CO₂, and CH₄.

HYDROGEN SULFIDE CONCENTRATIONS

Results for continuous H₂S measurements in the dairy cattle barns are summarized in Table 2. Concentration was monitored simultaneously at the sluice gate, the mid-length of the pit, and the nozzle. The total number of measurements at the three locations were not the same because of occasional loss of data due to inadvertent soaking of the sensors by splashed manure and/or water, or because of datalogger battery failure. The measurement duration varied depending on the time taken to flush the

TABLE 1. Properties, characteristics and TLVs of manure gases

| Property or Characteristic | Manure Gas | | | |
|----------------------------|------------------|-----------------|-----------------|-----------------|
| | H ₂ S | NH ₃ | CO ₂ | CH ₄ |
| Specific gravity | 1.2 | 0.6 | 1.5 | 0.6 |
| Odor | rotten egg | pungent | none | none |
| TLV-TWA ppm* | 10 | 25 | 5 000 | none† |
| TLV-STEL ppm* | 15 | 35 | 15 000 | none† |
| Hazard level volume %* | 0.05 | 0.2 | 30.0 | 5 to 15† |

* ppm = parts per million by volume; 1.0 volume % = 10 000 ppm.

† Asphyxiant, forms explosive mixture with air.

Table 2. Hydrogen sulfide concentration in dairy-cattle barn

| Description and Location | Gas Measurement Site and Season | | |
|--|---------------------------------|----------|-------------|
| | Milking-Cow Barn | | Heifer Barn |
| | Summer | Winter | Winter |
| <i>At Sluice Gate End</i> | | | |
| No. of measurements | 9 | 10 | 6 |
| Measurement duration - min | 96 - 253 | 78 - 377 | 132 - 395 |
| Peak concentration - ppm* | 15 - 62 | 11 - 63 | 5 - 41 |
| Average concentration - ppm† | 1 - 14 | 1 - 11 | 0 - 8 |
| Peak 15-min avg. concn. - ppm‡ | 6 - 31 | 1 - 42 | 2 - 30 |
| Duration of concn. > TLV-STEL-min§ | 0 - 46 | 0 - 43 | 0 - 14 |
| <i>Midway Between Sluice Gate and Nozzle</i> | | | |
| No. of measurements | 9 | 11 | 4 |
| Measurement duration - min. | 52 - 247 | 75 - 379 | 289 - 395 |
| Peak concentration - ppm* | 6 - 55 | 2 - 56 | 4 - 22 |
| Average concentration - ppm† | 0 - 12 | 1 - 6 | 0 - 1 |
| Peak 15-min avg. concn. - ppm‡ | 2 - 37 | 2 - 44 | 3 - 11 |
| Duration of concn. > TLV-STEL-min§ | 0 - 35 | 0 - 22 | 0 |
| <i>At the Nozzle End</i> | | | |
| No. of measurements | 10 | 11 | 4 |
| Measurement duration - min | 83 - 216 | 78 - 374 | 291 - 393 |
| Peak concentration - ppm* | 3 - 42 | 4 - 70 | 4 - 23 |
| Average concentration - ppm† | 1 - 17 | 1 - 9 | 0 - 2 |
| Peak 15-min avg. concn. - ppm‡ | 2 - 33 | 3 - 55 | 2 - 10 |
| Duration of concn. > TLV-STEL-min§ | 0 - 36 | 0 - 43 | 0 |

* Highest one-minute average concentration during the measurement period.

† $\frac{\sum \text{one-minute average concentration}}{\text{measurement duration in minutes}}$

‡ Continuous 15-minute period average concentration.

§ Continuous time period when the TLV-STEL of 15 ppm for H₂S was exceeded.

flush the manure out of the long pits, and the different durations of the monitoring period prior to, and after the mixing operation. As one would expect, the average concentration tended to be higher for the shorter than for the longer duration of measurement, and the peak concentrations were not affected by the measurement duration. Peak 15-min average concentrations in excess of 15 ppm, the TLV-STEL for H₂S, occurred at all locations except in the heifer barn at the nozzle and the mid-length locations. These concentration excursions beyond the TLV-STEL lasted from 0 to 46 min at different times and sites. The results in Table 2 indicate that the H₂S concentration varied widely even when the operational conditions and procedures were similar. The gas concentrations, however, were generally well below the hazard level; they were not much different for the summer and winter conditions. It appears that the higher slurry temperature and, presumably, a higher gas production rate in the summer than in the winter was compensated by the higher summer ventilation rate. There was a tendency for the gas concentration to be lower in the heifer barn than in the milking-cow barn. This may be partly due to differences in ventilation conditions and animal feed composition in the two barns.

Figures 3 and 4 illustrate the variation of H₂S concentration in the milking-cow barn in the summer and winter (slurry temperature of 20° and 9°C), respectively. The gas concentration increased sharply whenever there was turbulence and movement of slurry. The highest concentrations were generally recorded at the sluice gate where the turbulence was maximum. In general, peak concentrations were reached early during the slurry mixing

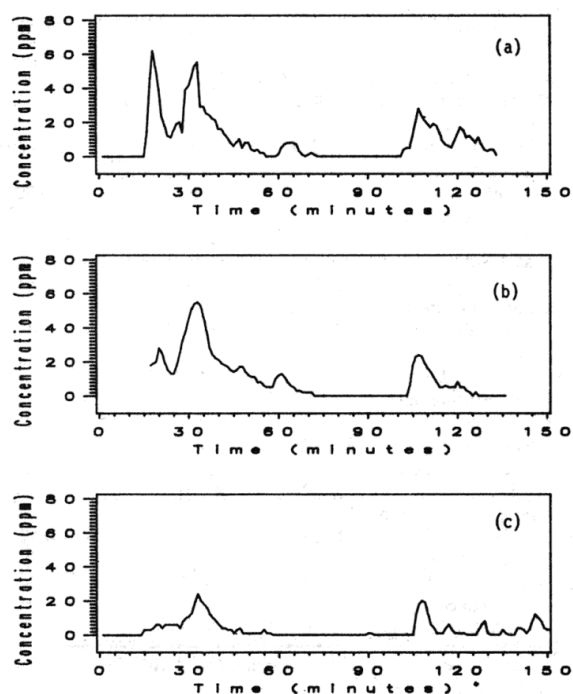

Figure 3—Hydrogen sulfide concentration variation near the sluice gate (a), mid-point along pit-length (b), and recirculation pipe nozzle (c) in the dairy barn (fig. 1) during summer. Monitoring started at min 0, recirculation pump started at min 5, sluice gate opened at min 15,

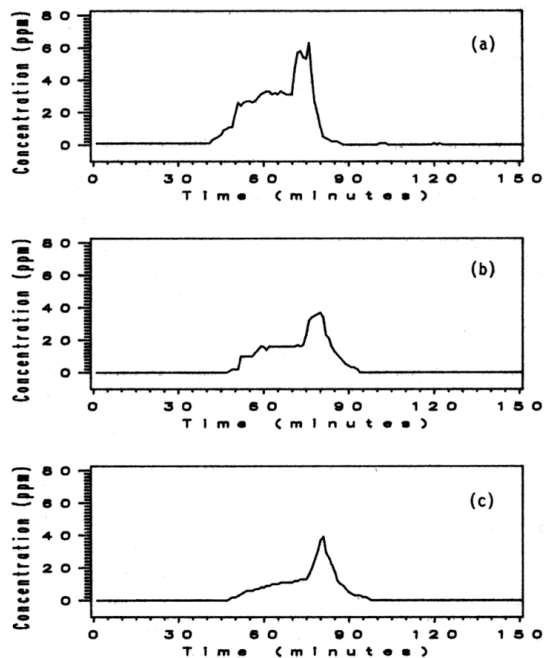

Figure 4—Hydrogen sulfide concentration variation near the sluice gate (a), mid-point along pit-length (b), and recirculation pipe nozzle (c) in the dairy barn (fig. 1) during winter. Recirculation pump started at min 45 to fill the pit, sluice gate opened at min 70.

period, and the peak duration ranged from about 2 to 15 min. The concentration decreased rapidly when the slurry movement was stopped, otherwise it decreased slowly to the initial levels as the mixing by circulation was continued after the sluice gate was opened. The results in Table 2 and figures 3 and 4 suggest that it would be impractical to apply the criteria of TLV-TWA and TLV-STEL for H₂S to farm situations during slurry mixing.

The very substantial and immediate effect of slurry agitation and turbulence on H₂S gas release was also evident in the swine barns. In swine barn A, the recirculating slurry was discharged below the slurry surface, and it did not splash around in the pit beneath the slats. The H₂S concentration was less than 3 ppm at all locations inside the barn and varied from 40 to 110 ppm in the pit exhaust air. This indicated a relatively low rate of release of dissolved H₂S from the slurry, and also the effectiveness of the pit fans in removing H₂S from the pit free-space.

In swine barn B (fig. 2), there was a 0.3 to 0.6 m deep floating crust in the pit. During mixing, the recirculation pump discharge pipe had to be momentarily lifted above the manure surface to make adjustments. A sudden rise in H₂S concentrations occurred immediately at this time in both the pit exhaust air (fig. 5) and inside the barn (fig. 6). During this time, the manure slurry was splashing around in the free-space beneath the slats. The detection limit of some of the detectors used was only 100 ppm. It is evident that this concentration, which is 10 times the TLV-TWA, was exceeded for a long period of time in pit exhaust PF2 (fig. 5a), and also at location M1 inside the barn, 1 m above the slats (at min 30 in fig. 6c). Concentration at the pig level was probably higher.

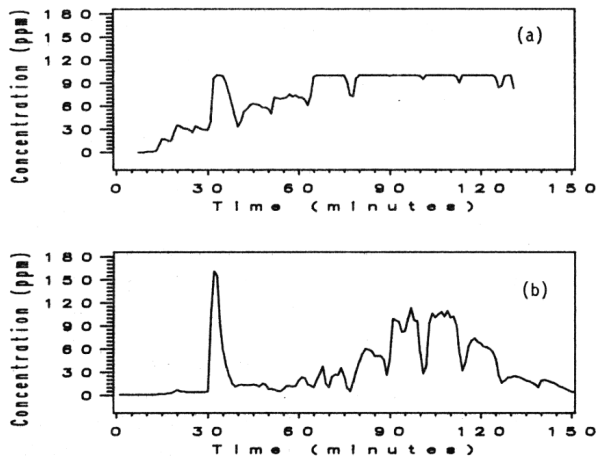

Figure 5—Hydrogen sulfide concentration variation in manure-pit exhaust air in swine Barn B at locations M4 (a) and M5 (b), 6 m and 12 m from the manure pump, respectively (see fig. 2). Detector detection limit was 100 ppm at M4 and 200 ppm at M5. Recirculation pump started at min 10 and the discharge pipe was momentarily raised above the manure surface at min 30.

Had the non-submergence of the discharge pipe, and the resultant splashing of the manure slurry beneath the slats persisted for an extended period of time, at least some of the pigs in the barn could have been exposed to hazardous concentrations of H₂S. It is noteworthy that this potentially hazardous, transient gas concentration excursion above the slats at min 30 lasted for 15 minutes only (fig. 6c) and it

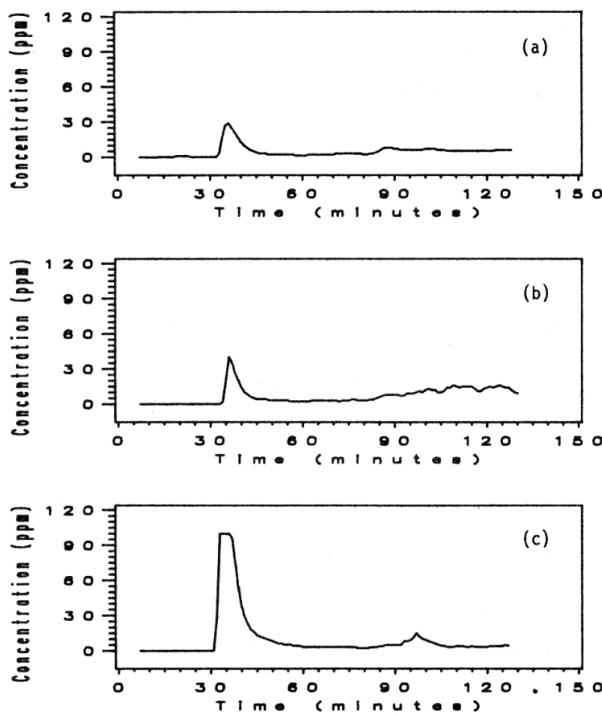

Figure 6—Hydrogen sulfide concentration variation inside swine barn B at locations M3(a), M2(b) and M1(c), 9.1, 10.3 and 5.7 m from the manure pump, and 1, 0 and 1 m above the slats, respectively. Detector detection limit was 100 ppm at all sites. Recirculation pump started at min 10 and the discharge pipe was momentarily raised at min 30.

would not have been detected if long-term or diffusion-type detector tubes were used for concentration measurement. Even with short-term detector tubes, such H₂S concentration peaks would be missed unless the measurement was made at precisely the time and location of the concentration excursion. The spatial variation of concentration was, to some extent, determined by the direction of the manure discharge nozzle because the concentration was higher near the splashing manure than further away.

Except for the peak at min 30, H₂S concentrations at all locations inside barn B remained below 20 ppm (fig. 6), an undesirable but not hazardous concentration for the relatively short time-period involved. Concentration in the pit exhaust air rose slowly as the crust broke, to levels well above 100 ppm, and this was followed by a slow decrease as the dissolved H₂S was depleted (fig. 5). The peaks and valleys for H₂S concentration resulted from periodic stopping and starting of manure mixing to fill tankers for hauling slurry to the field. It is estimated that the pit fans were exhausting 25 L of air/s/m² of barn floor area.

Figure 7 shows the immediate and rapid rise in H₂S concentration in the pit exhaust air in swine barn C when air was blown into the bottom of the pit to mix the manure. The concentration rose to 222 ppm in a 4-min period, and fell rapidly when the blowing of air was stopped. Had the mixing by this method continued, the concentration would have risen further. Also, had the pit exhaust fan not worked, the pigs in the vicinity would have been exposed to very high H₂S concentrations. At the time of H₂S concentration excursion, the pit fan was exhausting about 15L of air/s/m² of barn floor area. Unlike swine barn B, H₂S concentration above the slats near the pit exhaust duct did not at any time exceed the TLV-TWA (10 ppm) when air was blown into the stored manure. The turbulence and splashing in the slurry and the resultant release of H₂S was probably less in this barn than that produced by the submerged manure pump used for manure mixing in swine barn B.

Results in figures 5 to 7 clearly illustrate the rapid H₂S build up that can occur during manure mixing. Transient hazardous conditions could occur if the pit exhaust fans failed even for a short duration during mixing. It would be advisable to have an alarm system to warn against pit fan failure and possibly hazardous conditions in the barn, particularly during unattended slurry mixing.

Figure 8 shows H₂S concentration variation at the time of slurry mixing inside the caged-layer barn immediately above (fig. 8a) and below (fig. 8b) the hatch-opening cover.

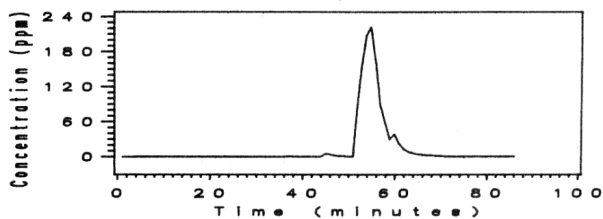

Figure 7—Hydrogen sulfide concentration variation in the pit exhaust air of swine barn C. Three tanker loads of manure were hauled away between min 30 and min 48. Manure was mixed by blowing air into the bottom of the manure pit from min 50 to 54.

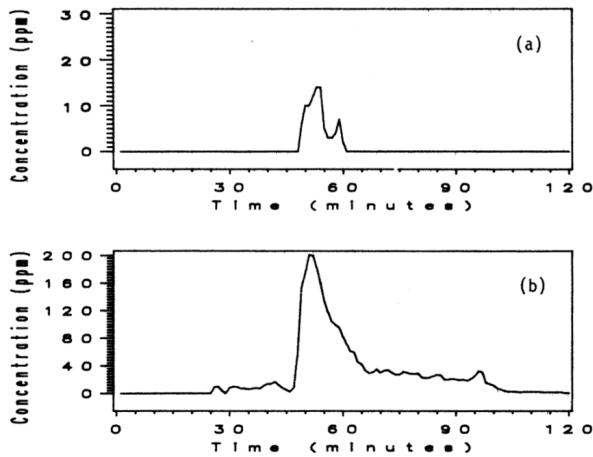

Figure 8—Hydrogen sulfide concentration variation in a caged-layer barn above (a) and below (b) a covered manure pit opening. Manure was mixed from min 24 to 40 with the recirculation nozzle submerged and from min 46 to 94 with the nozzle exposed in the pit free space; manure tankers were filled from min 41 to 46 and min 95 to 101.

cover. During the first mixing period (min 24 to 40), the 2.0 m deep pit was nearly full and the manure circulation pipe was submerged beneath the slurry surface. However, following the removal of the first tanker load, the manure circulation pipe was no longer submerged during the second (min 46 to 94) mixing period. When the circulation pipe was submerged, the highest H₂S concentration in the pit free space was 17 ppm, but with non-submerged pipe, the H₂S concentration rose from 9 ppm to 201 ppm in a four-min period (fig. 8b), and the concentration peak lasted for about 20 min. Had the hatch cover not been closed, H₂S release into the barn area immediately above the hatch opening could have endangered the poultry in the vicinity. Even with the hatch opening closed, H₂S concentration reached 14 ppm above the hatch. A small opening in the hatch cover (e.g., from an unsealed hatch cover) would have considerably increased this latter concentration. It is noteworthy that most of the dissolved H₂S in the slurry was depleted in a 20-min period. Similar concentration variation was observed in the second poultry barn.

CONCENTRATIONS OF OTHER GASES

Concentrations of NH₃ and CO₂, as determined by short-term, long-term, and diffusion-type detector tubes, were always below the TLV-TWA and TLV-STEL concentrations (Table 1) for these gases in all barns investigated (data not presented). Therefore, these gases did not present transient or longer-term hazardous conditions under normal ventilation conditions. Methane gas was not detected in the dairy barn with the natural-gas detector tubes. Methane concentrations were not determined in the swine and poultry barns.

CONCLUSIONS

- Of the four main manure gases, namely, H₂S, NH₃, CO₂, and CH₄, only H₂S release represents a potential hazard during manure slurry mixing. Gas concentrations can vary widely under apparently similar operational conditions.
- Release of dissolved H₂S is immediate and rapid when slurry mixing starts. Gas concentrations decrease

rapidly when mixing is stopped and slowly with prolonged mixing as the dissolved gas is depleted from slurry.

- Because of transient high-concentration peaks, time-weighted average concentration values of H₂S gas are of little value in terms of gas hazard indication during slurry mixing in animal buildings, because concentrations below TLVs may not indicate an absence of hazard from high H₂S concentrations.
- The degree of slurry turbulence and splashing in pit free space during mixing may be the dominant factor in the control of H₂S gas release and concentration inside barns compared to other factors such as animal diet and species, ventilation conditions, etc.
- From the operator and animal safety point of view, it is highly advisable to use a submerged recirculation pipe for mixing, and to prevent conditions of free-falling or splashing of manure slurry or blowing of air into slurry. This would also reduce odor nuisance from the release of H₂S and other odorous compounds when slurry is pumped from the barn into a remote, outdoor, open storage tank. Remote warning devices to indicate pit-fan failure would also be very useful, particularly during periods of unattended mixing operation, so that remedial action such as shutting off manure pump(s) could be implemented to reduce the hazard of manure gas. Other options would be to have a person present in the barn or to have it empty during slurry mixing, but these options may not be convenient to the farmer.

ACKNOWLEDGMENTS. The assistance of R. Allen, D. Campbell, R. Pella, C. Lynch, and other staff at the Animal Research Centre, and the cooperation of Frey Brothers, Haybay Farms, and G. Jantzi is gratefully acknowledged. This study was partially supported by the Ontario Ministry of Agriculture and Food under its Pork Industry Improvement Plan.

REFERENCES

ACGIH. 1983. Threshold limit values for chemical substances and physical agents in the work environment with intended changes for 1983-84. Amer. Conf. of Governmental Industrial Hygienists, Cincinnati, OH.

Agriculture Canada. 1979. *Canada animal manure management guide*. Publication 1534. Ottawa, Ontario: Agriculture Canada.

Anonymous. 1982. Pit-related deaths traced to unsafe agitation. *National Hog Farmer* (January 15):29-31.

Anonymous. 1986. Gas threat takes toll. *Hog Market Place Quarterly* (Winter) 1986:12.

Bodus, T. 1987. The air they breathe— How good (or how bad) is it? *Pork* 1987:24-31.

Dirksen, G. and E. Dahme. 1983. Hydrogen sulphide poisoning in cattle and its differential diagnosis. (In German). *Collegium Veterinarium* 14:104-108.

Donham, J.K., L.W. Knapp, M. Russel and K. Gustefson. 1982. Acute toxic exposure to gases from liquid manure. *J. Occup. Med.* 24:142-145.

Feilden, N.E.H. 1982. Toxic gases from slurry. *Farm Building Progress* (Scotland) (April) 7-10.

- Langer, I. 1982. Farm hand drowns in vat of manure, *Ottawa Citizen*, 18 October. (Ottawa, Ontario.)
- McAllister, J.S.V. and J.B. McQuitty. 1965. Release of gases from slurry. *Record of Agric. Res. N. Ireland* 14(2):73-78.
- Miner, J.R. 1981. Controlling odors from livestock production facilities. In *Livestock Waste: A Renewable Resource, Proc. 4th Intl. Symp. Livestock Wastes*. St. Joseph, MI: ASAE.
- Noren, O., S-U. Skarp and G. Anianson. 1967. *Recent experiences from JTI's studies on manure gas problem*. Circular No. 20. Uppsala, Sweden: Swedish Inst. of Agr. Engineering (JTI).
- O'Donoghue, J.G. 1961. Hydrogen sulphide poisoning in swine. *Can. J. Comp. Med. Vet. Sci.* 25:217-219.
- Simensen, E. 1987. Manure gases and manure gas poisonings in livestock production. *Vet. Hum. Toxicol.* 29(Supplement 2):61-62.
- Taiganides, E.P. and R.K. White. 1969. The menace of noxious gases in animal units. *Transactions of the ASAE* 12(3):359-362, 367.
- Turnbull, J.E., F.R. Hore and M. Feldman. 1971. A land recycling liquid manure system for a large-scale confinement operation in a cold climate. In *Livestock Waste Management and Pollution Abatement*, Publication PROC-271. St. Joseph, MI: ASAE.