

# MOBILITY AND PERSISTENCE OF ALACHLOR, ATRAZINE AND METOLACHLOR IN PLAINFIELD SAND, AND ATRAZINE AND ISAZOFOS IN HONEYWOOD SILT LOAM, USING FIELD LYSIMETERS

**BRUCE T. BOWMAN**

London Research Centre, Agriculture Canada, London, Ontario N6G 2V4, Canada

(Received 4 May 1989; Accepted 25 July 1989)

**Abstract-** Mobility and persistence of commercial formulations of alachlor, metolachlor and isazofos were studied under two moisture regimes using 75 x 15 cm field lysimeters. Formulated atrazine was also applied to each lysimeter for reference purposes. Alachlor- and metolachlor-treated lysimeters were packed with Plainfield sand, while Honeywood silt loam was used to pack isazofos-treated lysimeters. Effluent was monitored for each chemical, and selected cores were sectioned (7 x 10 cm) and analyzed to determine mobility profiles and persistence at weeks 1, 2, 4, 8, 12 and 21. The 50% disappearance times (DT50) for alachlor, atrazine, isazofos and metolachlor were: < 1.5, 4, 1.5 and 3 to 4 weeks, respectively. Water application during week 1, following pesticide application, created ponding on Honeywood soil cores, transporting atrazine and isazofos to a maximum 50-cm depth. While isazofos moved no further after week 1, atrazine and desethylatrazine (Des-Atr.) exhibited considerable mobility throughout the study. Ponding on Honeywood silt loam cores produced greater atrazine and Des-Atr. movement than in Plainfield sand cores. Des-Atr. production increased with soil moisture content. Relative mobilities in Plainfield sand were: Des-Atr. > atrazine > metolachlor > alachlor; in Honeywood silt loam: Des-Atr. > atrazine > isazofos.

**Keywords** - Herbicide Insecticide Leaching Soil core Desethylatrazine

## INTRODUCTION

There is a current trend in North American agriculture toward reduced tillage for crop production as a means of conserving soil resources. By reducing soil losses from wind and water erosion, the risk of aquatic contamination from applied pesticides should also be reduced. However, to compensate for less cultivation it is often necessary to increase dependence on herbicides for weed control, which again increases pollution risks. Concurrent with these trends is an increasing awareness and sensitivity by the public to contamination of drinking water sources by agrochemicals. This concern is further heightened by analytical methodology that continues to lower detectable limits for these compounds which in turn tend to quickly become legal tolerances. As a result, many widely used chemicals are coming under increased scrutiny by governmental agencies responsible for their registration and safe use.

Most land management practices that reduce soil erosion also reduce runoff volume to some degree, thereby increasing water retention [1,2] and the possibility of increased vertical water transport. The risk of groundwater contamination from vertical transport is ultimately determined by the balance between the rates of pesticide transport and degradation in the soil profile. This process can be short-circuited by tile drainage systems that intercept free water, and with it any chemicals that have not had the opportunity to degrade. It may therefore be prudent to closely monitor effluent from tile drains under reduced tillage systems following chemical application in May and early June, especially if above normal moisture conditions existed at application time.

During the past five years we have been developing a field lysimeter technique for studying vertical pesticide movement and degradation in soil cores [3,4]. This technique involves monitoring core effluent and determining the disposition of the pesticides within soil cores to characterize mobility and persistence under both prevailing rainfall conditions and a simulated irrigation program. Our goal has been to develop this technique, as a less expensive alternative to some full-scale field trials, for use in pesticide registration. This technique may also be useful for predicting potential pesticide losses via tile drainage systems since the lysimeter length is the minimum depth for many tile drains. Our research effort has focused on development of equipment and procedures for simulating field conditions, and several new modifications are reported in this study. For this technique to be useful in the registration process, we must demonstrate that it is both reliable and reasonably simulates field conditions. In this study we will examine the mobility and persistence of the herbicide atrazine in combination with each of two other herbicides, alachlor and metolachlor in Plainfield sand lysimeters, and the combination of atrazine with a soil insecticide, isazofos, in Honeywood silt loam lysimeters.

## MATERIALS AND METHODS

### *Compounds and application rates*

Analytical grade standards (99.7% purity), supplied by CIBA-GEIGY Canada Ltd., were used to determine atrazine, desethylatrazine, isazofos and metolachlor contents of soil and water samples. Commercially formulated products, supplied by CIBA-GEIGY Canada Ltd., were applied to the field lysimeters as follows: atrazine-Aatrex 480L (flowable suspension); isazofos-10% granular; metolachlor-Dual 960E (emulsifiable concentrate). (Dr. J. Gaynor, Harrow Research Station, Agriculture Canada, kindly supplied both analytical grade alachlor and Lasso 48% (emulsifiable concentrate).) Lysimeters were divided into three treatment groups (alachlor, isazofos, metolachlor) with atrazine applied separately to all lysimeters. Alachlor was applied to soil cores at 4.5 kg a.i./ha (8,290 µg/core), the maximum recommended rate when last used in 1985 [5]. Atrazine was applied at the maximum recommended rate of 2.25 kg a.i./ha (3,980 µg/core) [6]. Metolachlor was applied at its maximum recommended rate of 2.64 L a.i./ha (5,066 µg/core). Granular isazofos was applied at a rate of 4.25 kg a.i./ha (7,530 µg/core), 2.5 cm below the soil surface (at least 1.0 cm from outer edge of cylinder) by removing and replacing the top soil layer. The required amount of formulated products (alachlor, atrazine, metolachlor) in 10-ml aqueous suspensions were applied uniformly over the surface of each soil core, at least 1 cm away from the cylinder walls. Atrazine application was made to the isazofos cores after the granular isazofos had been applied and the surface soil layer replaced.

### *Experimental setup*

Details of the experimental setup, the leaching protocol and analytical procedures have been previously described [4,5]. Briefly, about 17 kg (dryweight) of Plainfield sand (Table 1) were loaded into each lysimeter of the alachlor and metolachlor sets (24 lysimeters per set) producing a 70 x 15 cm soil core packed to within 5 cm of the top of the stainless steel cylinder (Fig. 1). In the isazofos set, the lower 55 cm of the lysimeters was packed with the 15- to 100-cm horizon of Honeywood silt loam (Table 1). After saturating and allowing these cores to settle for 2 d, the top 15 cm was packed with the 0- to 15-cm horizon of Honeywood silt loam (Table 1). Lysimeters were buried in an outdoor sand-filled enclosure to within 5 cm of the top of the unit. Effluent was removed from the 1-liter collection beaker below the soil core via a stainless steel tube. A second tube from the soil surface to the support unit maintained an equalized air pressure at the core base while effluent was being removed. A fine screen was attached to the bottom of the support unit funnel and the space below the soil core was filled with fine quartz sand to enhance core drainage. A fine wire hung from this bottom screen also aided water drainage from the sand pack above it. Approximately 10 to 12 liters of water applied to each lysimeter over the twoweek period preceding treatment on 10 May 1988 aided uniform packing of the cores.

The set of 24 cores used for each test chemical was divided into two moisture regimes of 6 pairs each. One-half the lysimeters received natural rainfall only, while the remaining lysimeters received rainfall plus supplementary watering, simulating a 50-mm rainfall on day 2 and a 25-mm rainfall on day 9 (the second water application was reduced from 50 to 25 mm because of 32 mm of rain on days 7 and 8).

Table 1. Properties of soils used in mobility studies

Soil	%				Saturation moisture %
	Sand	Silt	Clay	O.M.	
Plainfield sand (1988)	87.5	6.5	6	1.5	32.1
Honeywood silt loam <sup>a</sup>	38.5	50	12	2.8	34.8
Honeywood silt loam <sup>b</sup>	43	43	14	1.5	34.1
Plainfield sand (1987)	91.5	1.5	7	0.7	29.7

O.M., organic matter.

<sup>a</sup> 0- to 15-cm horizon. <sup>b</sup> 15- to 100-cm horizon.

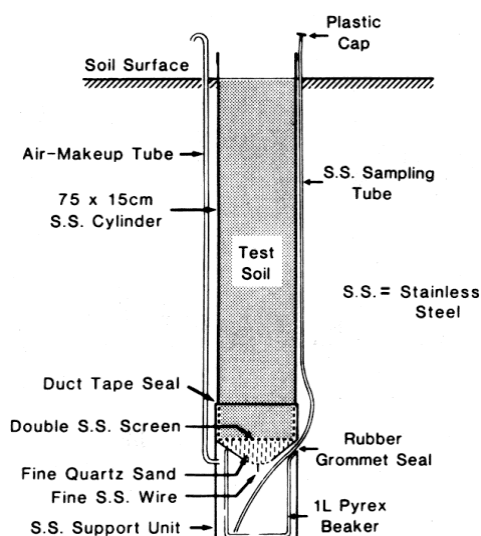

Fig. 1. Schematic representation of field-lysimeter unit.

After week two, 25-mm water applications were made: (a) 2 d following less than 10-mm rainfall, (b) 3 d following 10- to 25-mm rainfall, (c) 4 d following >25-mm rainfall, or the last watering. Effluent from each lysimeter was centrifuged at 40,000 g for 10 min and the supernatant analyzed for each chemical by HPLC or by GLC. One pair of cores from each moisture regime was retrieved from the field at 1, 2, 4, 8, 12 and 21 weeks and frozen for subsequent sectioning (7 x 10 cm) and residue analysis.

#### Soil core extraction and analysis

Glass sample bottles (450 ml, screw-capped) containing 100 g treated soil and 80 ml extraction solvent (90:10 HPLC-grade methanol:water) were heated in a circulating water bath to 45°C for 10 min, sonicated for 10 min and then tumbled for 30 min at 40°C in a temperature-controlled cabinet. Samples were left to settle for 30 min, then the supernatant was decanted into vacuum Buchner funnels and filtered (No. 2 Whatman, 8- $\mu$ m retention). The remaining soil slurries in the sample bottles were extracted a second time and added (total transfer) to the contents of the first

extraction in the Buchner funnels. The soil cake in each Buchner funnel was finally washed with 3 x 10 ml aliquots of extraction solvent. Filtrates were quantitatively transferred to 250-ml volumetric flasks, made to volume with methanol, and centrifuged at 40,000 g for 20 min to remove sediment traces before HPLC or GLC analysis.

Desethylatrazine analyses were done by HPLC (Table 2), while alachlor, atrazine and metolachlor were analyzed by HPLC and/or GLC. Isazofos was analyzed by only GLC. GLC operating parameters were: column, J&W 0.53 mm x 15 m megabore, 3.0  $\mu$ m film thickness; carrier gas, ultrapure He (8-20 ml/min.); detector, nitrogen-phosphorus, 260°C; H<sub>2</sub> flow rate, 1 to 3 ml/min plus He makeup gas for a total detector flow rate of 30 ml/min; injector temperature, 240°C; injection volume, 2.0 : l (auto-injected); temperature programs, 165°C initial, 10°C/min to 250°C. Atrazine eluted near 195°C, isazofos eluted near 200°C and metolachlor and alachlor eluted near 215°C. Minimum detectable concentrations for alachlor and metolachlor were about 15 : g/L, for atrazine 5 to 10  $\mu$ g/L, and for isazofos 0.5 : g/L. All mobile phase solvents for HPLC analyses were degassed by vacuum filtering through 0.7- : m glass microfiber filters. Peak areas of HPLC and GLC responses of alachlor, atrazine, isazofos and metolachlor were determined by a computing integrator using external standard solutions of the same solvent composition.

## RESULTS AND DISCUSSION

### Effluent data

Neither atrazine nor desethylatrazine appeared in the effluent of alachlor- or metolachlor-treated lysimeters containing Plainfield sand, under either supplementary watering (Fig. 2A) or rainfall (Fig. 2B) throughout the 21-week study. Metolachlor eluted twice from each of two supplementary watering cores (< 20  $\mu$ g/L), primarily following the 50- and 25-mm water applications during weeks one and two.

Table 2. HPLC analytical parameters

Compound	Mobile phase <sup>a</sup>	Flow rate (ml/min)	Wavelength (: m)	Injection vol. (: l)	Detection limit <sup>b</sup>
Des-atrazine	35/65	1	220	30	10
Atrazine					
Alachlor	58/42	1.4	200	50	15
Metolachlor					

Column - 5 mm x 10 cm reversed-phase (10 : m) C18 Radial-Pak (Waters).

<sup>a</sup> Acetonitrile/water ratio.

<sup>b</sup> Minimum detectable concentration (: g/L).

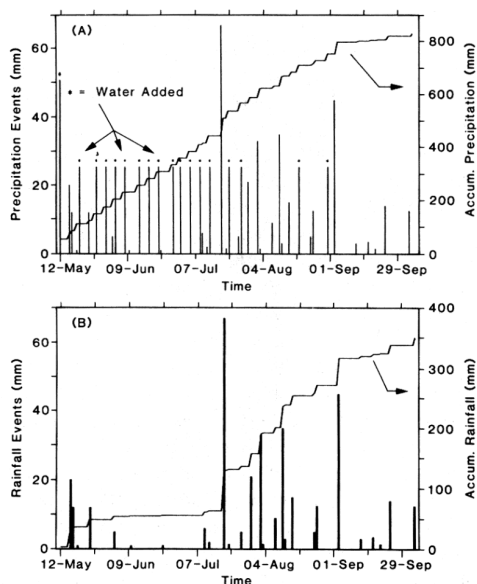

Fig. 2. London Research Centre Precipitation Record, 1988. (A) Rainfall plus supplementary watering, daily and accumulative. (B) Rainfall, daily and accumulative.

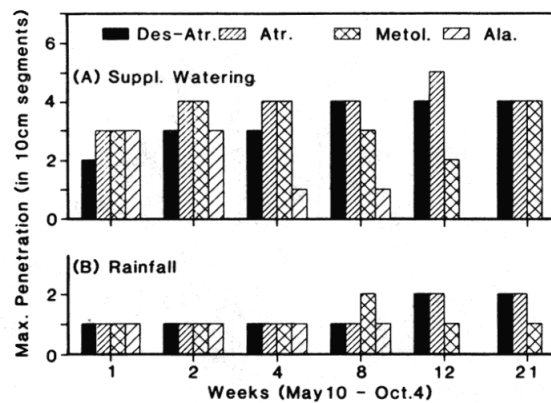

Fig. 3. Maximum penetration of alachlor, atrazine, desethylatrazine and metolachlor in Plainfield sand lysimeters. (A) Supplementary watering. (B) Rainfall. Ala. = alachlor; Atr. = atrazine; Des-Atr. = desethylatrazine; Metol. = Metolachlor.

In isazofos-treated cores packed with Honeywood silt loam, isazofos eluted on one or two occasions during week 1 from 9 of 12 cores ( $< 28 \mu\text{g/L}$ ) receiving supplementary watering, primarily on the day following water application. Isazofos eluted from only 2 of 12 rainfall cores ( $< 10 \mu\text{g/L}$ ) during week 1. No further isazofos elution was observed through the remainder of the study. Atrazine, in contrast, eluted from 9 of 12 supplementary watering cores throughout the study, with up to 19 separate elutions in some cores (usually  $< 40 \mu\text{g/L}$ ). Atrazine also eluted from two cores at 200 and  $100 \mu\text{g/L}$  on two successive days during week 1. In rainfall cores, there were four atrazine elutions from two cores at various times throughout the study ( $< 15 \mu\text{g/ml}$ ). Traces of desethylatrazine initially appeared in effluent from supplementary watering cores during week 3 ( $< 16 \mu\text{g/L}$ ), and by week 4 desethylatrazine was eluting from all cores, excepting one. Concentrations increased to a maximum of  $73 \mu\text{g/L}$  in early August, then slowly declined to less than  $20 \mu\text{g/L}$  in September. Desethylatrazine eluted on single occasions from five rainfall cores ( $2\text{--}14 \mu\text{g/L}$ ) in early July, but not thereafter.

#### Mobility and persistence data

*Plainfield sand.* Alachlor did not move beyond the top 10 cm of rainfall cores (Fig. 3B) during the 21-week study, which included a prolonged hot, dry period from late May to mid-July (Fig. 2B). Mobility profiles (plots of depth in core (segment no.) vs. fraction of applied chemical remaining) are not shown for chemicals that remained at or near the surface of soil cores throughout the study. Alachlor moved 30 cm down supplementary watering cores during week 1 (50 mm water, 35.3 mm rain), but moved no further (Fig. 3A) and totally disappeared by week 12 (Fig. 4) in both moisture regimes.

Because of lack of sensitivity in mobility profile plots for clearly showing penetration limits of the chemicals in soil cores, we show this information in maximum penetration bar graphs (Fig. 3). There are two important points to consider when interpreting these graphs: (a) cores were cut into  $7 \times 10 \text{ cm}$  segments, and data shown are the average amounts in each 10-cm segment; and (b) maximum penetration data (Fig. 3) show only the furthest extent to which a chemical was detected in a soil core, which of course is a function of analytical detection limits. A balanced perspective comes from correlating this information with respective mobility profiles showing amounts transported.

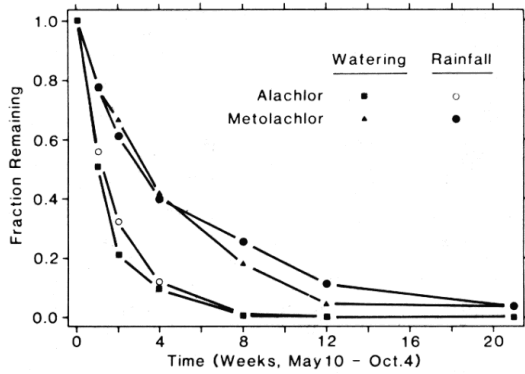

Fig. 4. Persistence of alachlor and metolachlor in Plainfield sand lysimeters under both rainfall and supplementary watering.

Metolachlor did not move below 10 cm in rainfall cores, with the exception of a small amount reaching the second segment (20 cm) by week 8 (Fig. 3). By week 12, remaining metolachlor was again confined to the top 10 cm, probably a result of degradation (Fig. 4). During week 1 in supplementary watering cores (50 mm water, 35.3 mm rain), about 10% of applied product moved below 10 cm, with maximum penetration of 30 cm (Figs. 3, 5). By week 2 (75 mm water, 49 mm rain), an additional 1.5% of applied pesticide had moved to 40 cm. Maximum penetration receded to 30 and 20 cm, at weeks 8 and 12, respectively, but with increased rainfall during September again moved to 40 cm. DT50 values for metolachlor under both moisture regimes (Fig. 4) was 3 to 3.5 weeks, slightly longer than the 2.5 week value reported in 1987 [4] but almost the same as 1986 results [3].

Movement and persistence of atrazine and desethylatrazine were quite consistent in both alachlor- and metolachlor-treated core sets, and averaged data are presented in Figures 6 and 7. The amount of desethylatrazine present is expressed as the molar "fraction remaining" of applied atrazine. As a result of extremely dry, hot conditions from late May until mid-July, neither atrazine nor desethylatrazine moved beyond 10 cm in rainfall cores until week 12 (Fig. 3), at which time it reached maximum depth of 20 cm.

In supplementary watering cores, maximum movement of atrazine was 30 and 40 cm during weeks one and two (Fig. 3), respectively, while desethylatrazine lagged by one 10-cm segment each week. Maximum movement was 40 cm at week 8 for both chemicals, with atrazine moving to 50 cm at week 12 and receding again to 40 cm by week 21, probably a result of degradation. Atrazine's DT50 values in Plainfield sand were about four weeks for both moisture regimes, slightly longer than observed in 1987 in Plainfield sand of slightly different texture and 50% less organic matter (Table 1) [4].

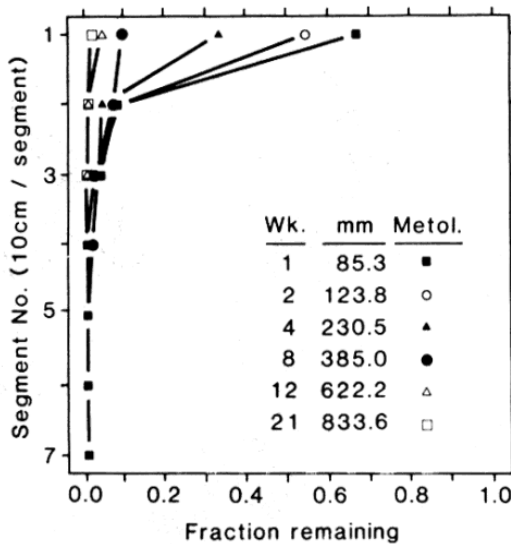

Fig. 5. Mobility profiles for metolachlor in Plainfield sand lysimeters under supplementary watering.

The 50% disappearance time (DT50) for alachlor in Plainfield sand cores for both moisture regimes was 7 to 10 d (Fig. 4), similar to 11 d reported by Petersen et al. [7]. Van Rensburg and van Dyk [8] reported that alachlor disappearance rate increased with decreasing moisture and increasing temperature. After 15 d, they found only 23.3 and 29.1% of applied alachlor remaining at 25°C, at field capacities of 50 and 100%, respectively. In this study, moisture contents of soil core surface layers, under both moisture regimes, were near 50% of field capacity during the first few weeks (Table 1). Judging from Beestman and Deming's data [9] (50% of applied alachlor volatilized in 12-29 d when exposed to 3.2 km/h air movement), volatilization losses in this study may have been of comparable importance to degradation losses since a surface application was used.

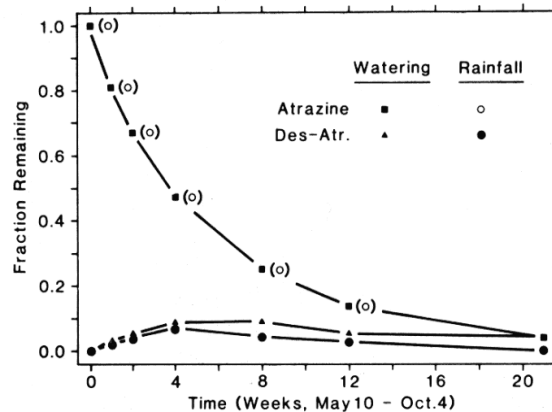

Fig. 6. Persistence of atrazine and desethylatrazine in Plainfield sand lysimeters under both rainfall and supplementary watering. Des-Atr. = desethylatrazine.

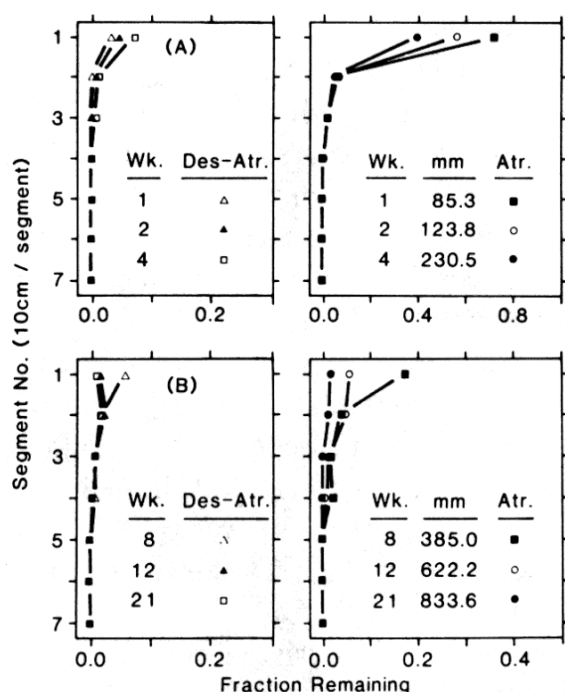

Fig. 7. Mobility profiles for atrazine and desethylatrazine in Plainfield sand lysimeters under supplementary watering. (A) Weeks 1 to 4. (B) Weeks 8 to 21. Atr. = atrazine; Des-Atr. = desethylatrazine.

Approximately 2% (rainfall) to 3% (supplementary watering) of applied atrazine was converted to desethylatrazine during week 1 (Fig. 6), with levels continuing to increase until week 4 in rainfall cores (6.5 to 7.5% conversion) and until week 8 in supplementary watering cores (8.7 to 9.5% conversion). The higher, more consistent moisture contents of supplementary watering cores, relative to rainfall cores, appeared to favor atrazine conversion to desethylatrazine. Judging from maximum penetration data (Fig. 3) and soil mobility profiles (Fig. 7), atrazine and desethylatrazine appeared to be almost equally mobile in Plainfield sand. Accurate mobility comparisons based on these data are difficult since (a) atrazine concentrations ranged from 10- to 40-fold greater and (b) desethylatrazine conversion occurred in situ and could have only been transported from that point downwards.

The source of Plainfield sand used in this study was changed from the 1987 studies, and properties such as organic matter content were different (Table 1). Soil/water partitioning coefficients ( $K_d$ ) were somewhat larger for the 1988 Plainfield sand (Table 3), and atrazine mobility was correspondingly less [4]. Besides moving deeper into the cores in 1987, atrazine also appeared in the effluent of supplementary watering cores on a number of occasions. No atrazine eluted in 1988. Metolachlor, being less mobile than atrazine, was less sensitive to changes in soil properties and exhibited similar mobilities in both soils.

**Honeywood silt loam.** Atrazine, desethylatrazine and isazofos exhibited substantial movement during week 1 (Fig. 8), primarily as a result of three rainfalls (2.5 mm, day 2; 20 mm, day 7; 12 mm, day 8, Fig. 2). The larger two rainfalls that followed the 50-mm water supplementary watering application (day 2) did not increase maximum movement, relative to rainfall cores, but substantially increased amounts of atrazine, and especially desethylatrazine which moved (Figs. 9, 10). Maximum penetration at week one in supplementary watering cores was 40 cm for all three chemicals (Fig. 8), and in rainfall cores was 50 cm for atrazine and isazofos and 40 cm for desethylatrazine.

Table 3. Freundlich adsorption isotherm parameters for chemical-soil systems used in the 1987 and 1988 field mobility studies

Compound	Soil	Horizon (cm)	Freundlich parameters	
			Slope (N)	$K_d^a$
Alachlor	Plainfield sand		0.867	1.050
Atrazine	Plainfield sand		0.774	0.843
Desethylatrazine	Plainfield sand		0.782	0.489
Metolachlor	Plainfield sand		0.867	1.013
Atrazine	Honeywood s. loam	0-15	0.905	1.288
Desethylatrazine	Honeywood s. loam	0-15	0.824	0.858
Isazofos	Honeywood s. loam	0-15	0.805	2.828
Atrazine	Honeywood s. loam	15-100	0.723	0.669
Desethylatrazine	Honeywood s. loam	15-100	0.835	0.355
Isazofos	Honeywood s. loam	15-100	0.903	1.336
Atrazine	Plainfield sand (1987)		0.852	0.350
Metolachlor	Plainfield sand (1987)		0.840	0.661

<sup>a</sup> Units of  $K_d$ :  $\mu\text{g}^{(1-N)} \text{g}^{-1} \text{ml}^N$ .

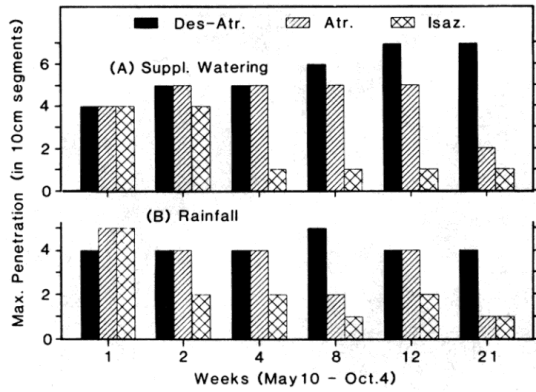

Fig. 8. Maximum penetration of atrazine, desethylatrazine and isazofos in Honeywood silt loam lysimeters. (A) Supplementary watering. (B) Rainfall. Atr. = atrazine; Des-Atr. = desethylatrazine.

Although traces of isazofos moved quickly to 40 and 50-cm depths, total amounts below 10 cm never exceeded 2% of applied product throughout the study, under both moisture regimes. In fact, maximum isazofos penetration occurred during week one and declined thereafter, possibly due to degradation processes or upward migration.

Atrazine and desethylatrazine both showed much greater mobility than did isazofos (Figs. 8-10). Both compounds frequently appeared in the effluent, with desethylatrazine consistently eluting after week three. In supplementary watering cores (Fig. 9), desethylatrazine was more mobile than atrazine, as reported by Muir and Baker [10]. Desethylatrazine levels in the soil increased until week eight (23.3 and 16.1 % of originally applied atrazine in supplementary watering and rainfall cores, respectively), after which levels steadily declined (Fig. 11).

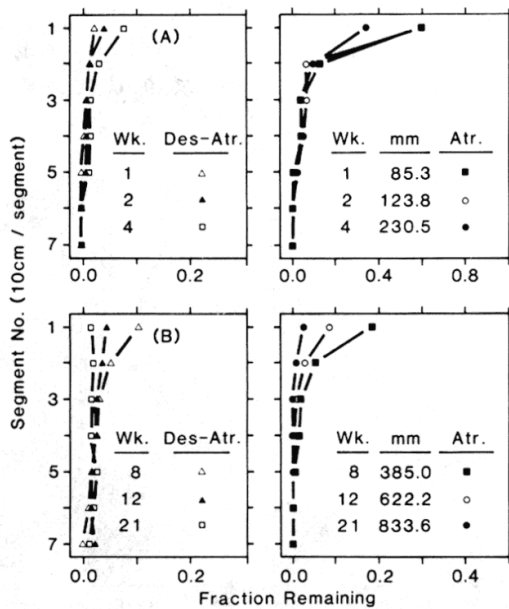

Fig. 9. Mobility profiles for atrazine and desethylatrazine in Honeywood silt loam lysimeters (isazofos-treated set) under supplementary watering. (A) Weeks 1 to 4. (B) Weeks 8 to 21. Atr. = atrazine; Des-Atr. = desethylatrazine.

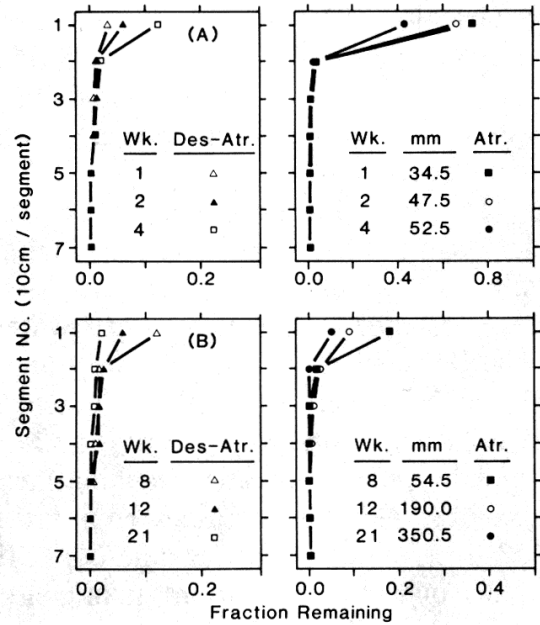

Fig. 10. Mobility profiles for atrazine and desethylatrazine in Honeywood silt loam lysimeters (isazofos-treated set) under rainfall. (A) Weeks 1 to 4. (B) Weeks 8 to 21. Atr. = atrazine; Des-Atr. = desethylatrazine.

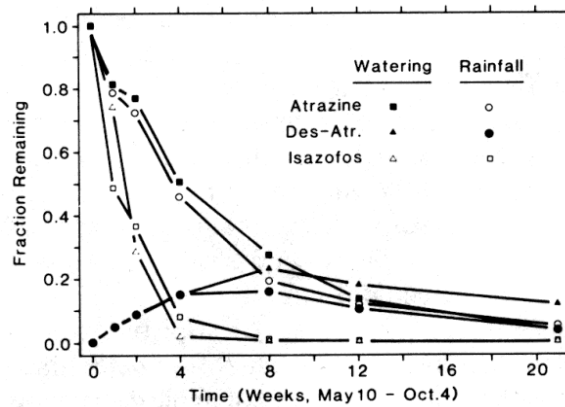

Fig. 11. Persistence of atrazine, desethylatrazine and isazofos in Honeywood silt loam lysimeters under both rainfall and supplementary watering. Des-Atr. = desethylatrazine.

These conversion values compare well with the 10 to 20% conversion reported by Sirons et al. in a clay loam soil [11]. Maximum desethylatrazine production in this soil, relative to that in Plainfield sand (Fig. 6), was about 2-fold and 2.5-fold greater in rainfall and supplementary watering cores, respectively.

The DT50 values for atrazine under both moisture regimes in this soil were similar to Plainfield sand values of about four weeks, with slightly greater persistence in supplementary watering cores. The DT50 values for isazofos were approximately 1 to 1.5 weeks, which, like alachlor, did not last sufficiently long to move substantial distances and become a potential leaching hazard. These isazofos persistence values compare well with a 13-d value obtained in Minnesota (CIBA-GEIGY, personal communication), taking into account the prolonged period of high temperatures during our 1988 study.

Greater leaching of atrazine and isazofos in this soil immediately following application and subsequent rainfall, relative to Plainfield sand, was initially unexpected (Figs. 3, 8).

This finer textured soil with almost twice the organic matter content of Plainfield sand (Table 1) was considerably more retentive for atrazine in batch adsorption studies (Table 3). However, Plainfield sand cores had the greater water infiltration rate, and were relatively drier at treatment time than Honeywood soil cores. The 50-mm water application to supplementary watering cores on day 2 was ponded on the surface of Plainfield cores less than 1.5 h, compared with 8 to 10 h on Honeywood cores. A 50-mm water application on Plainfield sand cores required 24 to 48 h to complete elution, compared with 48 to 72 h for Honeywood silt loam cores.

It appears that the near-saturated state of Honeywood cores at treatment time, combined with the extended ponding period following water application, permitted more formulated atrazine and isazofos to be solubilized and transported by mass flow than occurred in the drier Plainfield sand cores. Ponding situations often occur naturally in depressional areas of moderate to heavy textured soils following heavy rainfalls and it is conceivable that should such rains occur soon after pesticide application similar rapid transport as observed here could occur.

*Soil moisture relationships.* Moisture content of lysimeter cores plays a key role in determining both mobility and persistence of applied chemicals. If these lysimeter data are to be useful in predicting solute behavior under actual field situations, it is important that water relations in the soil cores mimic field conditions as closely as possible. To minimize effects of continual saturation at the lysimeter bases (equivalent to a perched water table), we installed a fine stainless steel screen on the bottom of the funnel in the support unit, filled it with fine quartz sand and hung a fine stainless steel wire from the screen as a further drainage aid (Fig. 1). Laboratory tests showed improved drainage compared to the earlier design [3,4]. The quartz sand pack retained minimal amounts of chemicals and insignificant amounts of effluent relative to applied amounts. Saturation moisture percentages (Table 1) were 32.1 and 34.8% for Plainfield sand and Honeywood silt loam, respectively. Maximum moisture contents measured at core bases (both soils, both moisture regimes) were at least 6 to 7% below saturation levels (Figs. 12, 13).

As might be expected, supplementary watering cores of both soils were wetter and maintained more uniform moisture profiles throughout the study than rainfall cores. Despite the extreme drought conditions that persisted from late May until mid-July (Fig. 2B), the bottom half of Plainfield lysimeters under rainfall (Fig. 12B) still maintained moisture contents of 9 to 20%. It appears that moisture reserves in these lysimeters were sufficient to maintain surface moisture similar to what might be found under actual field situations, even through prolonged dry periods.

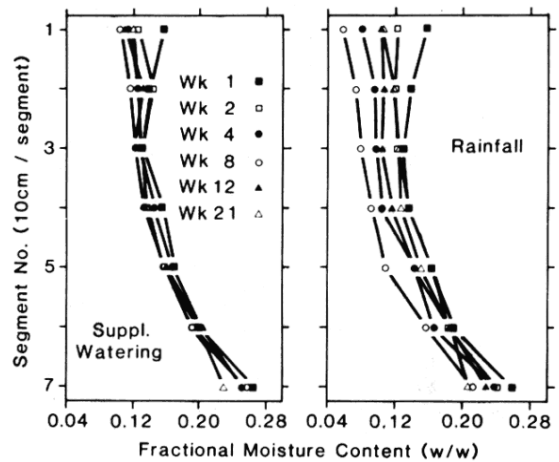

Fig. 12. Plainfield sand lysimeter moisture profiles. (A) Supplementary watering. (B) Rainfall. Saturation moisture percentage = 32.1.

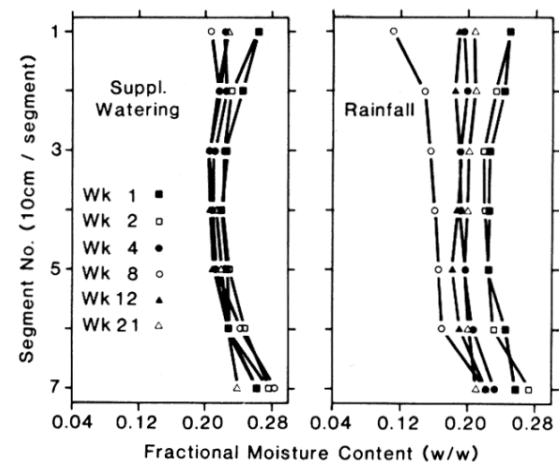

Fig. 13. Honeywood silt loam lysimeter moisture profiles. (A) Supplementary watering. (B) Rainfall. Saturation moisture percentage = 34.8.

In summary, there are a number of important observations to be noted from this study:

1. As reported in previous studies persistence data from these lysimeters for the various chemicals seem representative of values reported for similar soils and climatic conditions. The relatively short soil persistence of alachlor and isazofos in this study substantially reduced their leaching potential.
2. The mobility rankings for the pesticides were:
  - a) Plainfield sand: desethylatrazine > atrazine > metolachlor > alachlor.
  - b) Honeywood silt loam : desethylatrazine > atrazine > isazofos.
3. Ponding of water on medium to heavy textured soils following heavy rains, and soon after chemical application, may produce rapid and substantial movement, especially if the soils were quite wet at treatment time. More porous, lighter textured soils with higher water infiltration rates may be less susceptible to this sudden transport as a result of ponding.
4. Soil mobility profiles generated with this lysimeter system for the various chemicals corresponded well with respective soil/water partitioning coefficients, which may permit development of predictive capabilities for this technique.
5. Mobility and effluent data from these lysimeters may prove useful in predicting the appearance of chemicals in tile drains, which are usually buried 0.7 to 1.5 m deep in the soil and which can be major contributors to water pollution if there is significant rainfall following chemical application.
6. The severe drought persisting from late May until mid-July reduced the effectiveness of many field dissipation studies in 1988, thereby hampering registration efforts. This was the second consecutive year in which unusually dry conditions hindered these field studies. In contrast, this field lysimeter protocol provided useful transport, persistence and effluent data throughout both growing seasons. These lysimeters have proven quite consistent in their performance over the past four years, and should be a useful supplement to full-scale trials in assessing both mobility and persistence of candidate materials.

*Acknowledgment* - The author acknowledges the assistance of Mr. John Armistead and Mr. Aaron Kogon in the collection and analysis of the data used in the preparation of this manuscript. Additional funding support for this study was provided by both CIBA-GEIGY Canada Ltd. and the Ontario Ministry of Agriculture and Food.

## REFERENCES

1. **Stewart, B.A.** 1976. Control of water pollution from cropland. Vol. I. A manual for guideline development. U.S. Department of Agriculture Report ARSH-5-1. Washington, DC.
2. **Wagenet, R.J.** 1987. Processes influencing pesticide loss with water under conservation tillage. In T.J. Logan, J.M. Davidson, J.L. Baker and M.R. Overcash, eds., *Effects of Conservation Tillage on Groundwater Quality*. Lewis Publishing, Chelsea, MI, pp. 189-204.
3. **Bowman, B.T.** 1988. Mobility and persistence of metolachlor and aldicarb in field lysimeters. *J. Environ. Qual.* **17**:689-694.
4. **Bowman, B.T.** 1989. Mobility and persistence of the herbicides atrazine, metolachlor and terbutylazine in Plainfield sand using field lysimeters. *Environ. Toxicol. Chem.* **8**:485-491.
5. **Ontario Ministry of Agriculture and Food.** 1985. Guide to Chemical Weed Control. Publication 75. Toronto, Ontario, Canada.
6. **Ontario Ministry of Agriculture and Food.** 1988. Guide to Weed Control. Publication 75. Toronto, Ontario, Canada.
7. **Petersen, B.B., P.J. Shea and G.A. Wicks.** 1988. Acetanilide activity and dissipation as influenced by formulation and wheat stubble. *Weed Sci.* **36**:243-249.
8. **Van Rensburg, E. and E.P. van Dyk.** 1986. The persistence in soil and phytotoxicity on dry beans of alachlor and metolachlor as affected by climatic factors. *S. Afr. J. Plant Soil* **3**:95-98.
9. **Beestman, G.B.** and J.M. Deming. 1974. Dissipation of acetanilide herbicides from soils. *Agron. J.* **66**:308-311.
10. **Muir, D.C. and B.E. Baker.** 1976. Detection of triazine herbicides and their degradation products in tile-drain water from fields under intensive corn (maize) production. *J. Agric. Food Chem.* **24**:122-125.
11. **Sirons, G.J., R. Frank and T. Sawyer.** 1973. Residues of atrazine, cyanazine and their phytotoxic metabolites in a clay loam. *J. Agric. Food Chem.* **21**:1016-1020